

Study of Sensor Calibration Consistency

Jack Xiong

Sciences and Exploration Directorate, NASA/GSFC, Greenbelt, MD 20771, USA

Other Contributors: A. Wu (NASA) and C. Cao (NOAA)



CEOS WGCV 28th Meeting, Sanya, China (26-29 February, 2008)



Outline



- Why Calibration Consistency Matters
- Inter-Calibration Approaches
 - SNO, ground targets, lunar viewing, a third sensor, aircraft, etc.
- Using SNO for Sensor Calibration Consistency
 - MODIS, AVHRR, AASTR
- Issues and Challenges (open discussions)
 - Spatial and spectral



MODIS Instrument Calibration



Terra since Dec. 1999



- 20 Reflective solar bands (RSB): 0.41-2.2 μ m
- 16 Thermal emissive bands (TEB): 3.7-14.4 μ m
- 3 spatial resolutions at nadir: 250m, 500m and 1000m
- 4 Focal Plane Assemblies (FPA): VIS, NIR, SMIR, LWIR
- 5 On-Board Calibrators: SD, SDSM, SRCA, BB, and SV port

MODIS On-orbit Calibration: OBCs

Aqua since May 2002

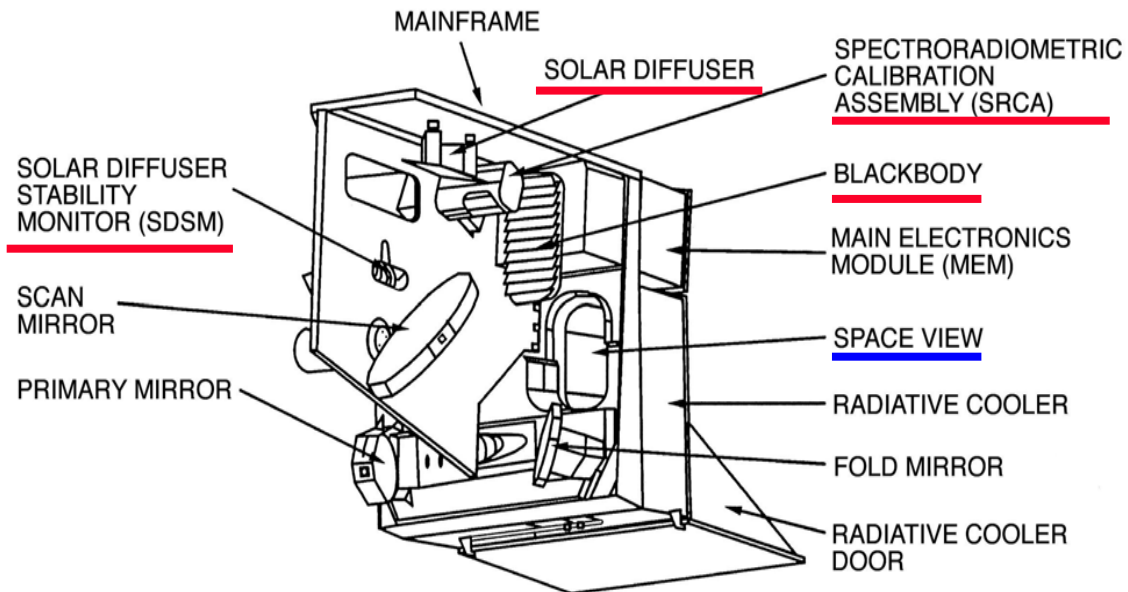

Plus Regular Lunar Observations

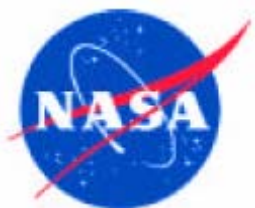

Using SNO for Sensor Inter-calibration



N-16 vs. Aqua (06/04/2006)

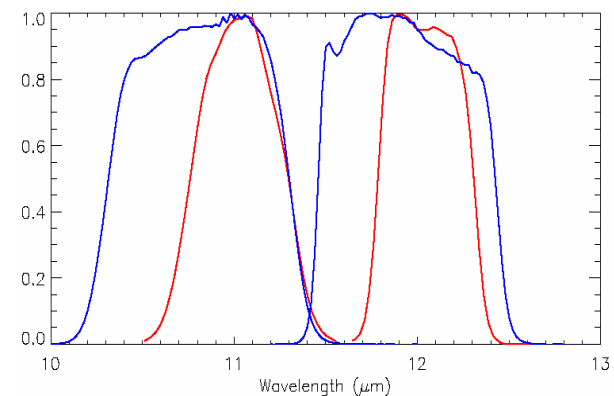
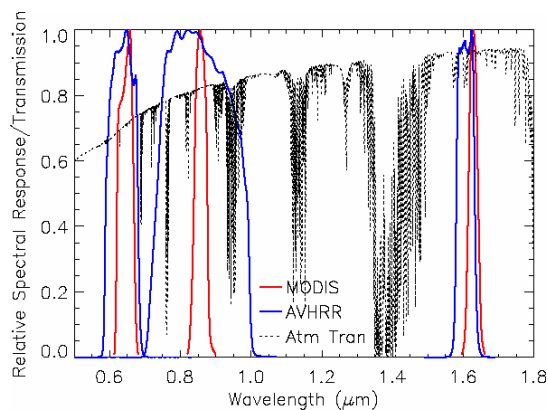
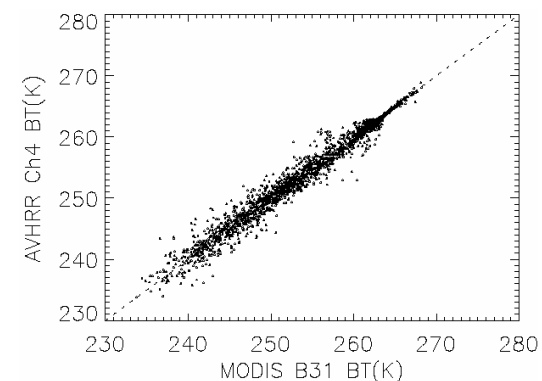
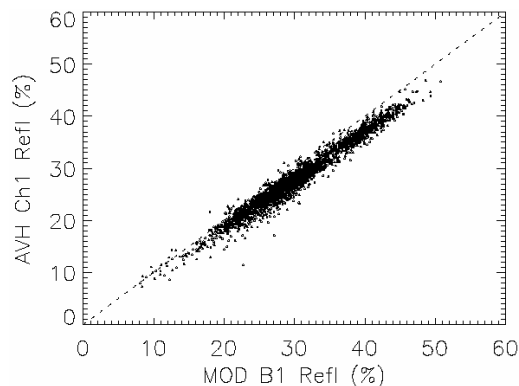
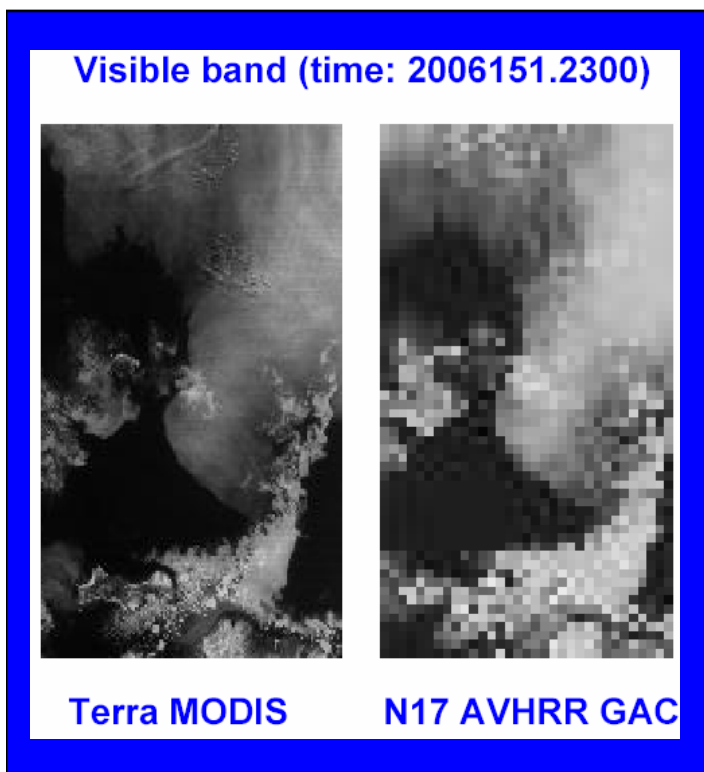



Using SNO for Sensor Calibration Consistency (Example: 1)

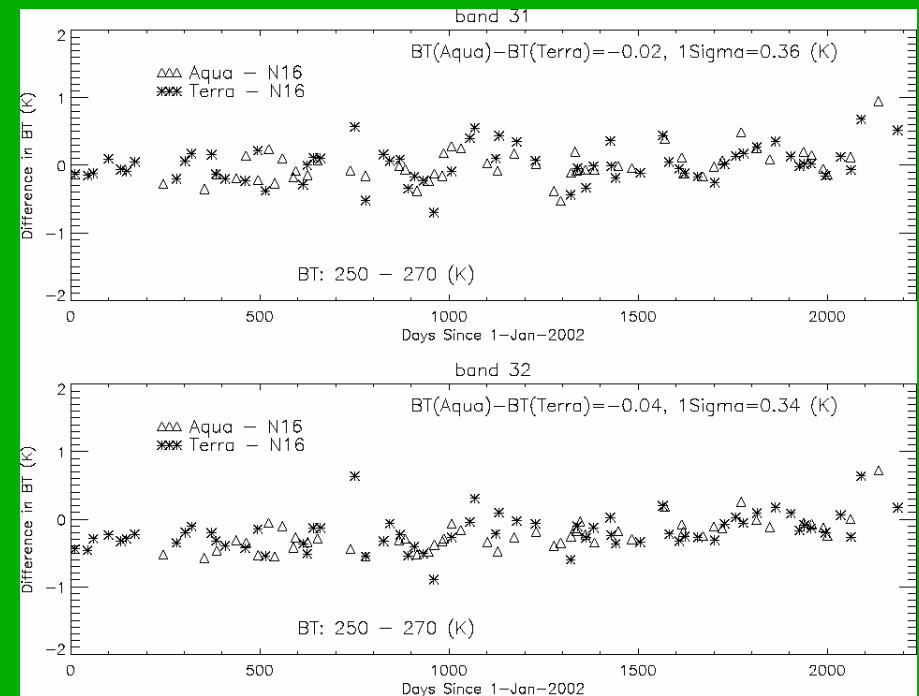
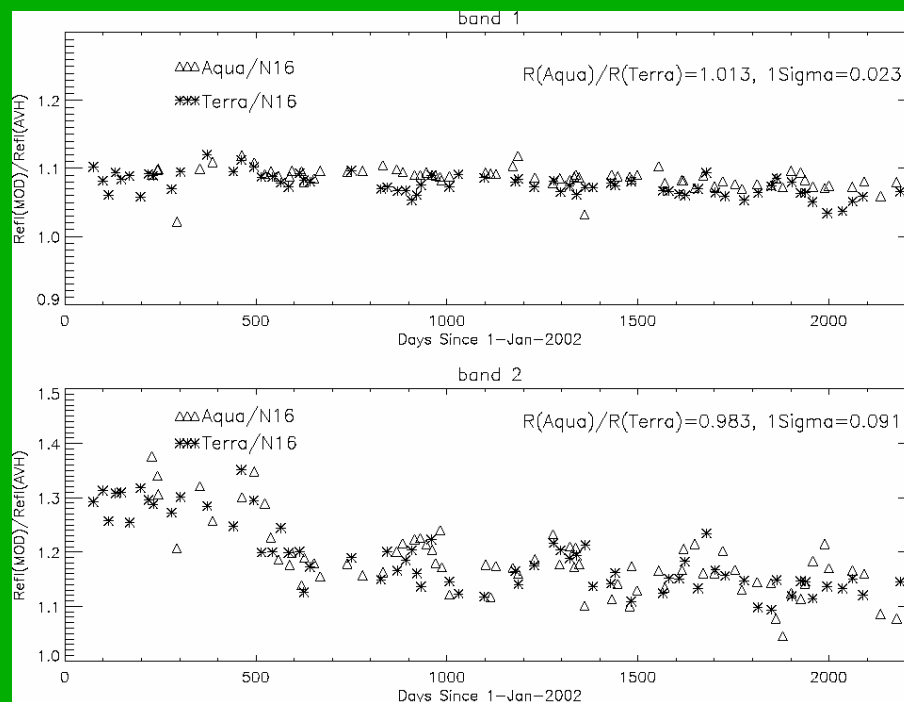

Using AVHRR to Study Terra and Aqua MODIS



Using SNO for Sensor Calibration Consistency (Example: 2)

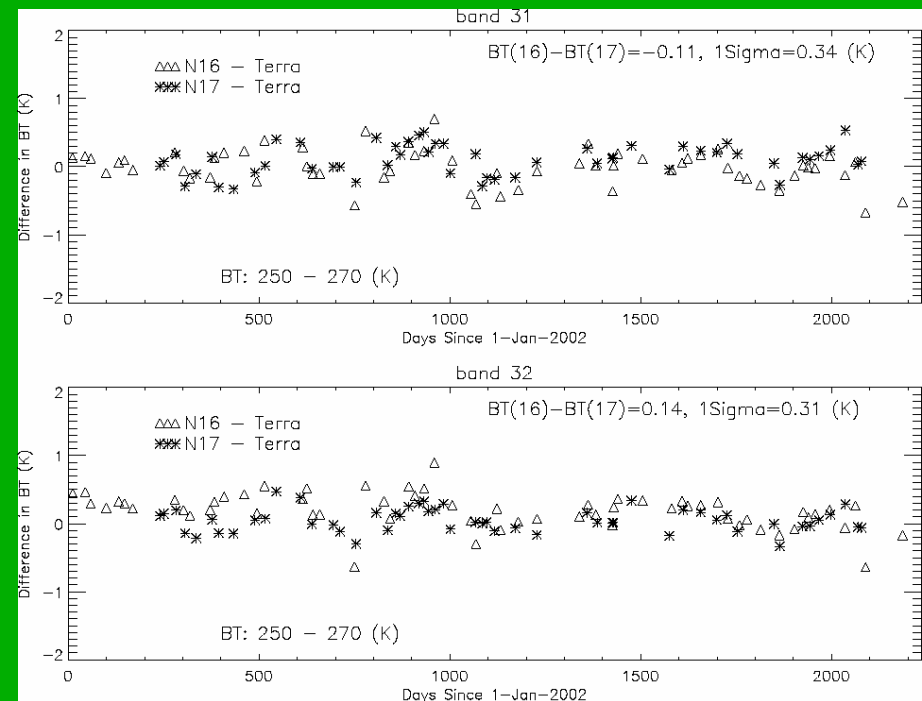
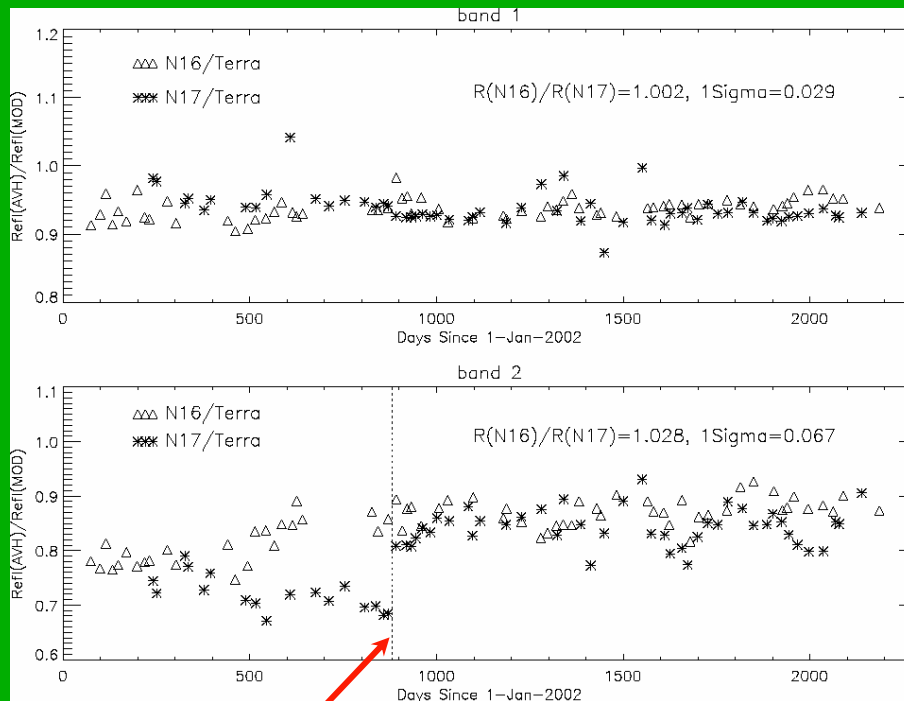

Gain Reset for
N17 AVHRR Ch.2

Using MODIS to Study AVHRR 16 and 17



Using SNO for Sensor Calibration Consistency (Example: 3)



GMT Time: 2007322.2115
Location: 81.1°S, 69.0°E

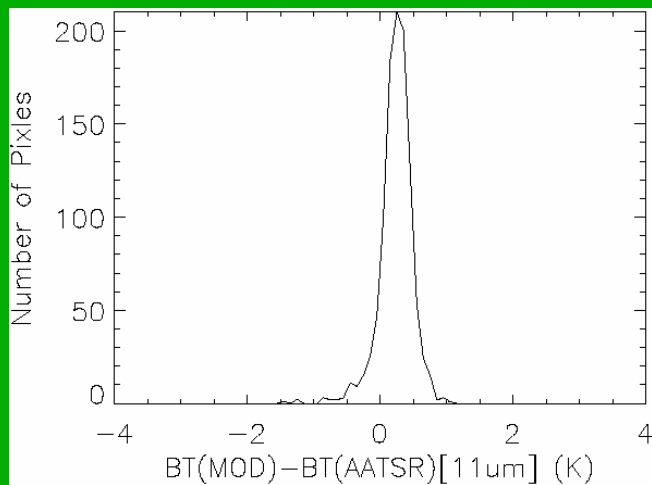
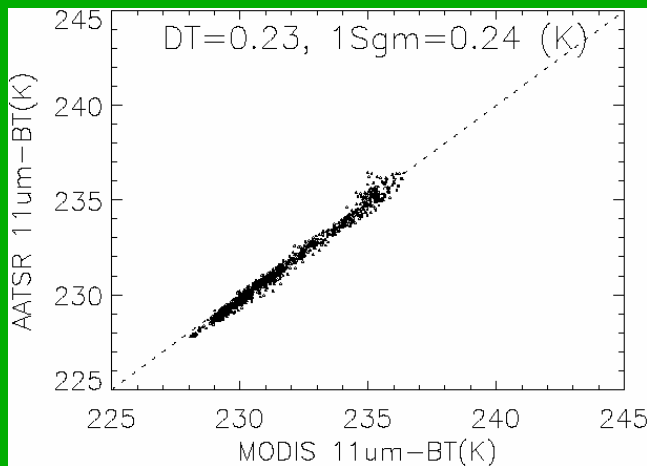

MODIS and AASTR Calibration Comparison

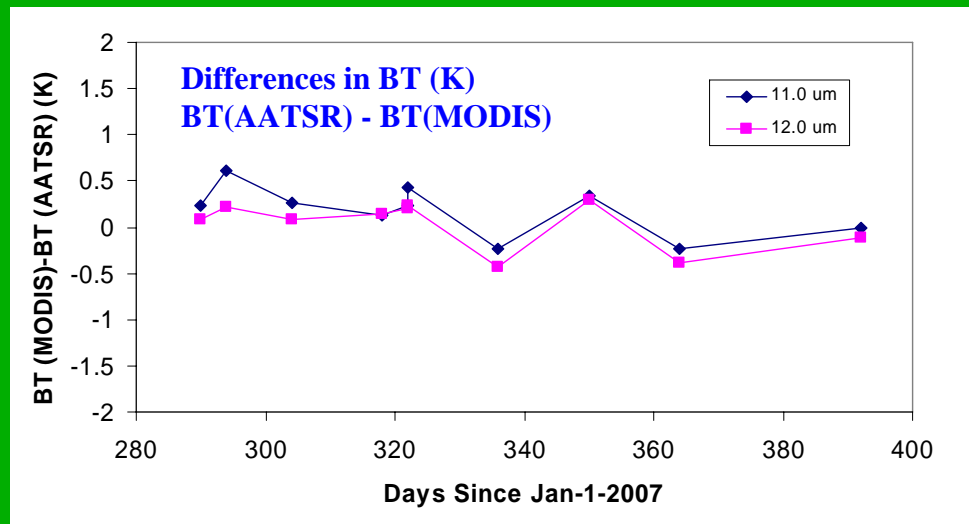

Limited work on AASTR reflective solar bands
(Coordination with D. Smith, RAL, UK)



MODIS Key Specifications



Primary Use	Band	Bandwidth ¹	Spectral Radiance ²	Required SNR ³	Primary Use	Band	Bandwidth ¹	Spectral Radiance ²	Required NEΔT(K) ⁴
Land/Cloud/Aerosols Boundaries	1	620 - 670	21.8	128	Surface/Cloud Temperature	20	3.660 - 3.840	0.45 (300K)	0.05
	2	841 - 876	24.7	201		21	3.929 - 3.989	2.38 (335K)	0.2
Land/Cloud/Aerosols Properties	3	459 - 479	35.3	243	22	3.929 - 3.989	0.67 (300K)	0.07	
	4	545 - 565	29	228	23	4.020 - 4.080	0.79 (300K)	0.07	
	5	1230 - 1250	5.4	74	Atmospheric Temperature	24	4.433 - 4.498	0.17 (250K)	0.25
	6	1628 - 1652	7.3	275		25	4.482 - 4.549	0.59 (275K)	0.25
	7	2105 - 2155	1	110	Cirrus Clouds Water Vapor	26	1.360 - 1.390	6	150 ³
Ocean Color/ Phytoplankton/ Biogeochemistry	8	405 - 420	44.9	880		27	6.535 - 6.895	1.16 (240K)	0.25
	9	438 - 448	41.9	838		28	7.175 - 7.475	2.18 (250K)	0.25
	10	483 - 493	32.1	802	Cloud Properties	29	8.400 - 8.700	9.58 (300K)	0.05
	11	526 - 536	27.9	754	Ozone	30	9.580 - 9.880	3.69 (250K)	0.25
	12	546 - 556	21	750	Surface/Cloud Temperature	31	10.780 - 11.280	9.55 (300K)	0.05
	13	662 - 672	9.5	910		32	11.770 - 12.270	8.94 (300K)	0.05
	14	673 - 683	8.7	1087	Cloud Top Altitude	33	13.185 - 13.485	4.52 (260K)	0.25
	15	743 - 753	10.2	586		34	13.485 - 13.785	3.76 (250K)	0.25
16	862 - 877	6.2	516	35		13.785 - 14.085	3.11 (240K)	0.25	
Atmospheric Water Vapor	17	890 - 920	10	167		36	14.085 - 14.385	2.08 (220K)	0.35
	18	931 - 941	3.6	57	¹ Bands 1 to 19 are in nm; Bands 20 to 36 are in μm ² Spectral Radiance values are (W/m ² -μm-sr) ⁴ NEΔT = Noise-equivalent temperature difference				
	19	915 - 965	15	250					