



GSICS UV sub-group: GOME-2 hyper-spectral radiances for cross-calibration and calibration of imager data



Rose Munro, Rüdiger Lang, Gabriele Poli, Antoine Lacan, Christian Retscher, Michael Grzegorski, Alexander Kokhanovsky, Rasmus Lindstrot, Richard Dyer and Ed Trollope

GSICS UV sub-group

Preliminary ideas on working topics

2013-11-13 : First meeting - Formation of GSICS UV sub-group

2014-12-16: Selection of UV-chair (Rose Munro, EUMETSAT)

Preliminary ideas for working-targets:

- **Reflectivity and Aerosol Index comparisons (340 nm - 390 nm)** by using vicarious methods for ocean, desert and ice sheet targets.
- **Solar measurement comparisons** by using high resolution reference data sets along with instrument band-passes and Mg II scale factors.
- **Comparisons of radiance/irradiance measurements (240 nm – 290/340 nm)** by using initial measurement residuals with respect to a priori ozone profiles
- **Identify calibration requirements and capabilities**
- ...

GSICS UV sub-group

Preliminary ideas on working topics

2013-11-13 : First meeting - Formation of GSICS UV sub-group

2014-12-16: Selection of UV-chair (Rose Munro, EUMETSAT)

Preliminary ideas for working-targets:

- **Reflectivity and Aerosol Index comparisons (340 nm - 390 nm)** by using vicarious methods for ocean, desert and ice sheet targets.
- **Solar measurement comparisons** by using high resolution reference data sets along with instrument band-passes and Mg II scale factors.
- **Comparisons of radiance/irradiance measurements (240 nm – 290/340 nm)** by using initial measurement residuals with respect to a priori ozone profiles
- **Identify calibration requirements and capabilities**
- ...



GOME-2 hyper-spectral radiances for (inter-)calibration

Outline

- GOME-2A / GOME-2B calibration
- GOME-2 / OMPS NPP calibration
- GOME-2 / AVHRR Metop calibration
- GOME-2 Metop / Seviri MSG calibration
- AVHRR calibration of GOME-2 pointing and FOV



Timelines for the Metop / GOME-2 level 1 products

Processor versions: Reprocessed and NRT data

- Metop-A GOME-2 (FM3) launched in Oct 2006
- Metop-B GOME-2 (FM2) launched in-orbit 17th September 2012
- Metop-C GOME-2 (FM1) 2018 (TBC)

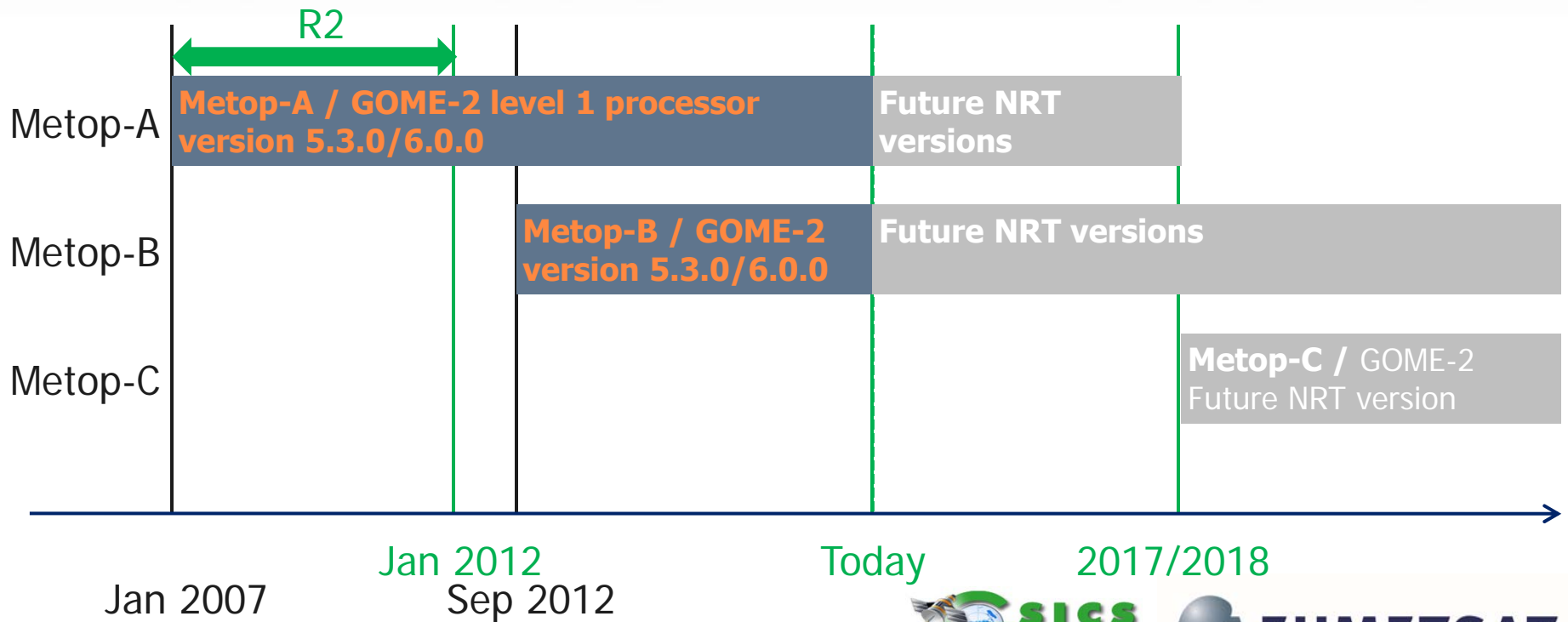

Metop-A/B GOME-2 inter-calibration

Earthshine co-located Metop-A/B measurements – co-locations

GOME-2 FM3
Metop-A

GOME-2 FM2
Metop-B

10th January 2013

Co-locations FM2 (M01) vs FM3 (M02) residuals for M01 +-48.2 min-shift viewing

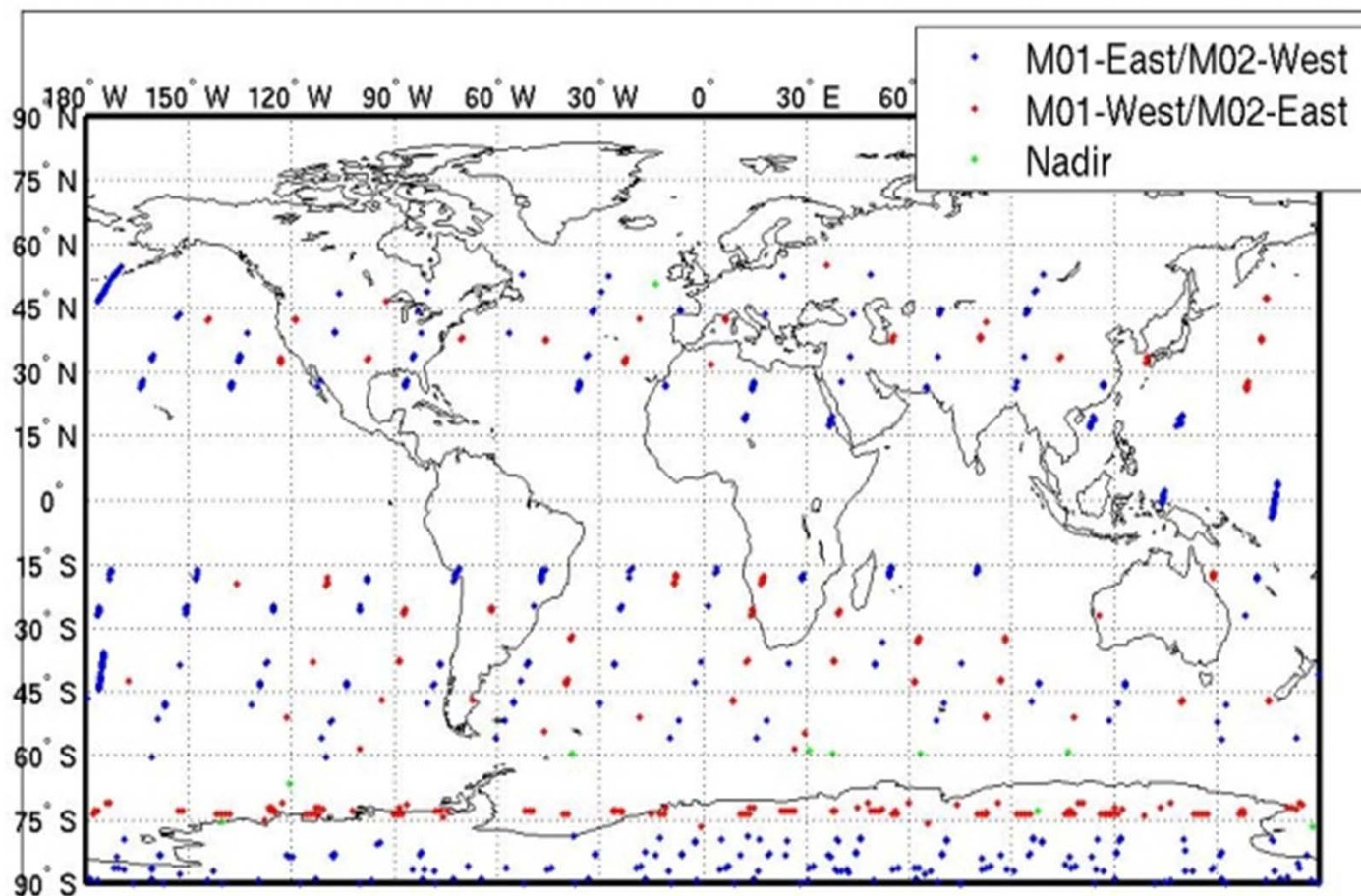

Metop-A/B GOME-2 inter-calibration

Earthshine measurement co-location FM2 to FM3 / Co-location criteria

GOME-2 FM3
Metop-A

GOME-2 FM2
Metop-B

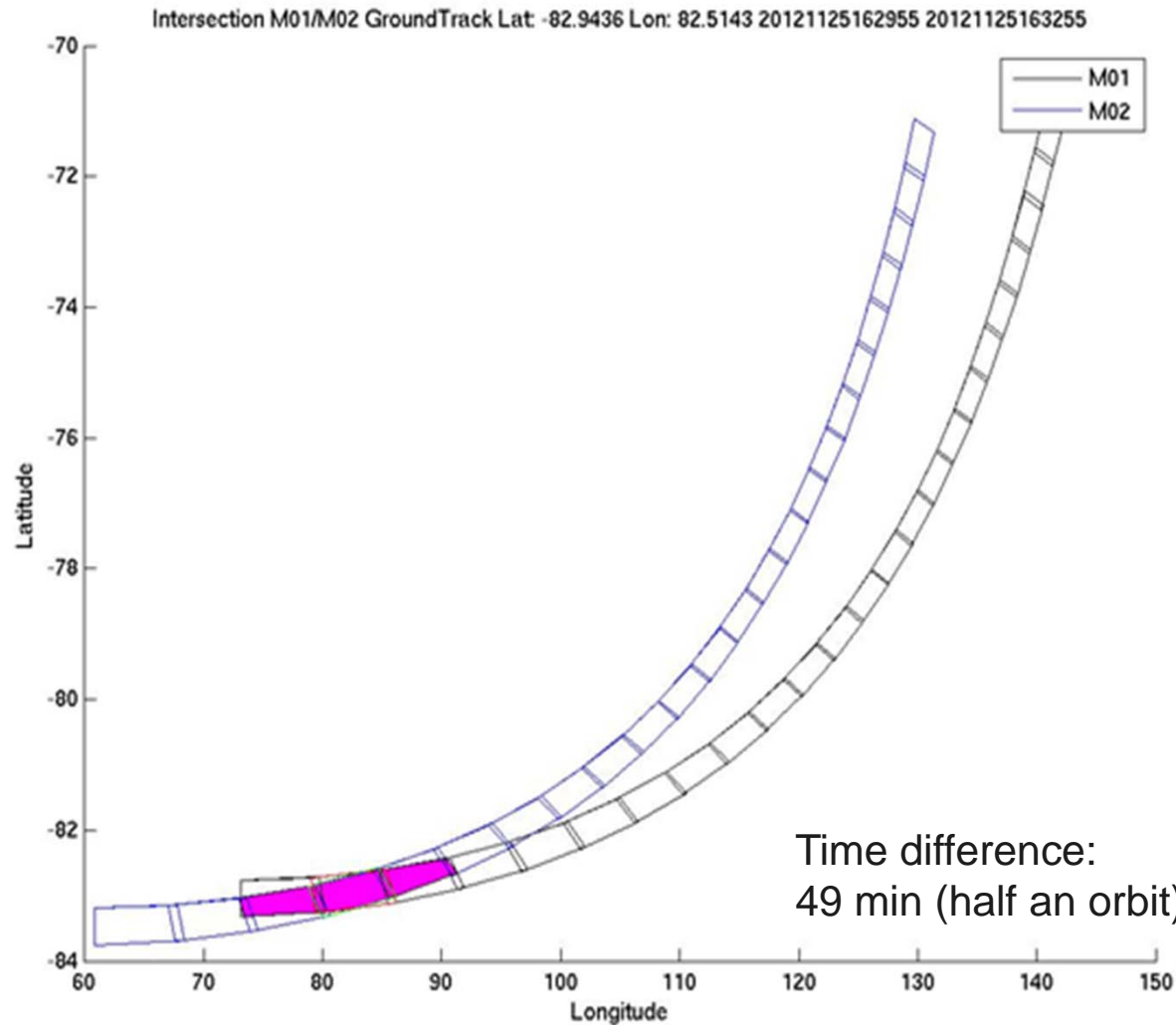

Metop-A (M02): FM3
Metop-B (M01): FM2

Co-location criteria:

- Area overlap > 80%
- Geo. AMF diff < 2%
- Relative O₂ A-Band residual (ROR) smaller than empirical threshold

Metop-A/B GOME-2 inter-calibration

Earthshine co-located Metop-A/B reflectances and residuals

GOME-2 FM3
Metop-A

GOME-2 FM2
Metop-B

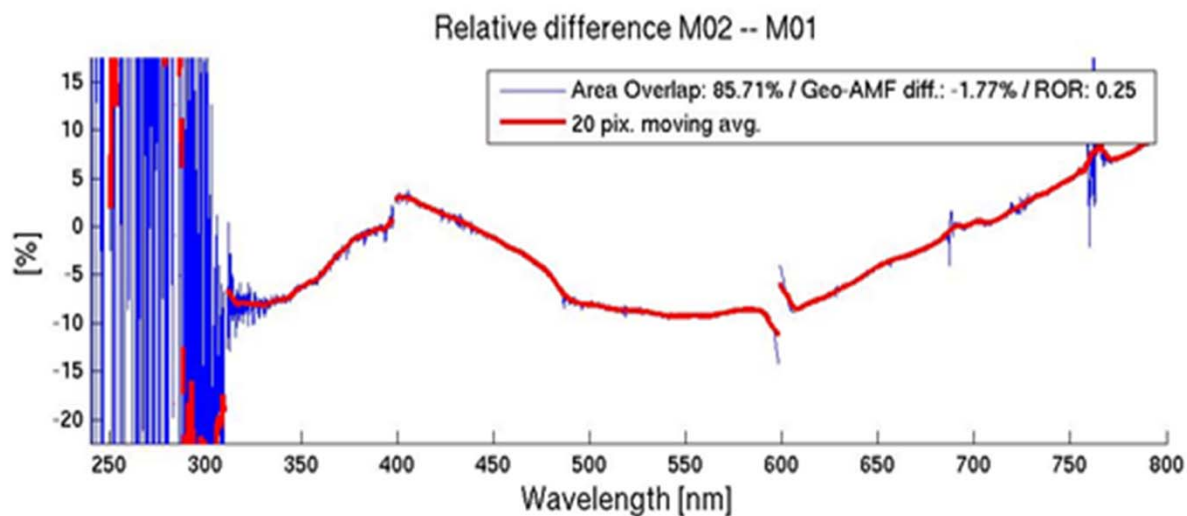
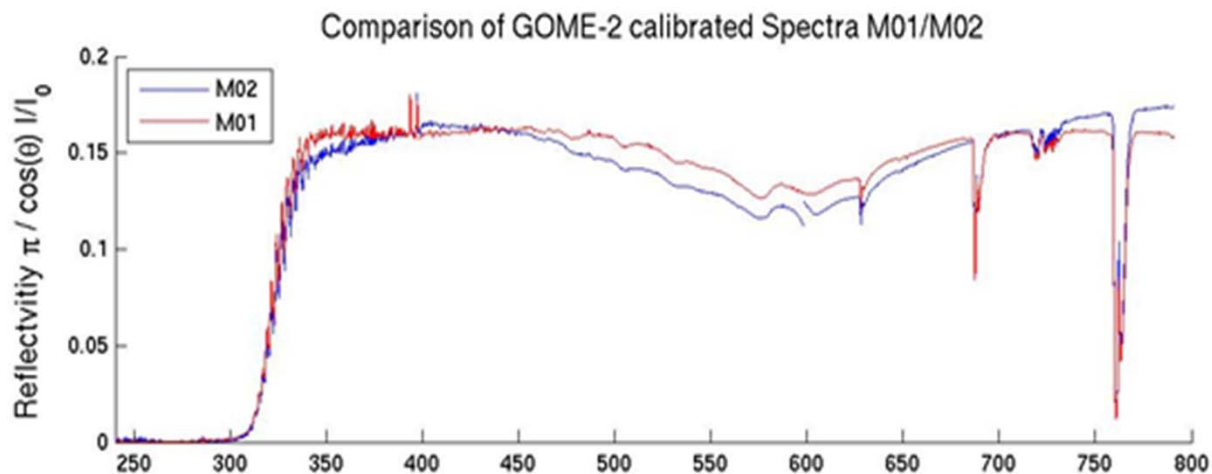

Residual in reflectivity
 + Lin. background
 subtracted per channel
 + 20 pix. moving average
 smoothing
 + Relative Oxygen-A band
 Residual (ROR) selection
 criterium

Metop-A/B GOME-2 inter-calibration

Earthshine co-located Metop-A/B residuals /
Global average with background subtracted

GOME-2 FM3
Metop-A

GOME-2 FM2
Metop-B

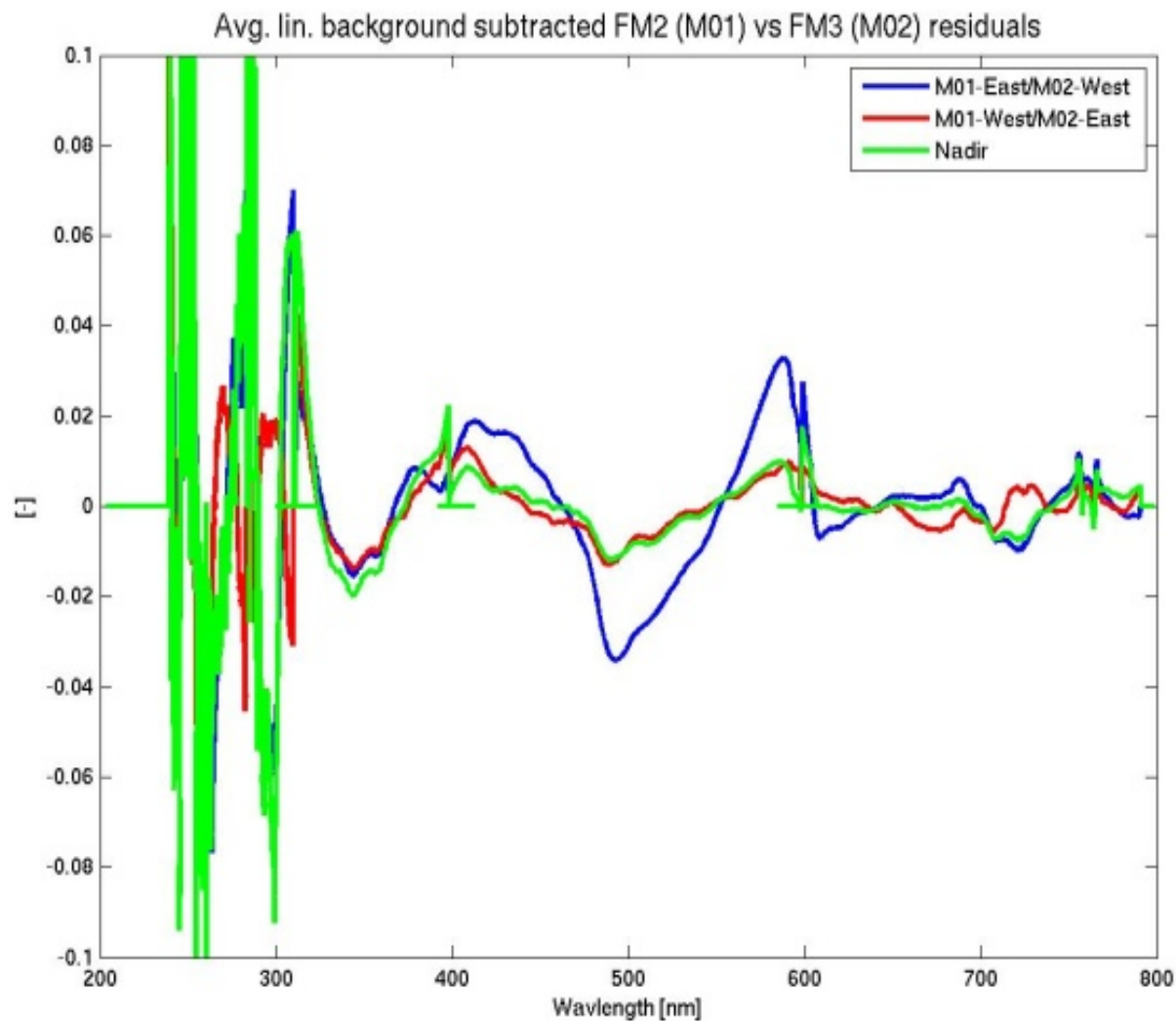

FM2-East/FM3-West
FM2-West/FM3-East
Nadir

Separation between
East/West/Nadir at
+/- 20 degree
viewing-angle

Metop-A/B GOME-2 inter-calibration

Earthshine co-located Metop-A/B residuals /
Interpretation with forward model – V-LIDORT

GOME-2 FM3
Metop-A

GOME-2 FM2
Metop-B

*Which instrument model contributes what
to the residual?*

Left up: **Residual Metop-A with V-LIDORT**
Residual Metop-B with V-LIDORT

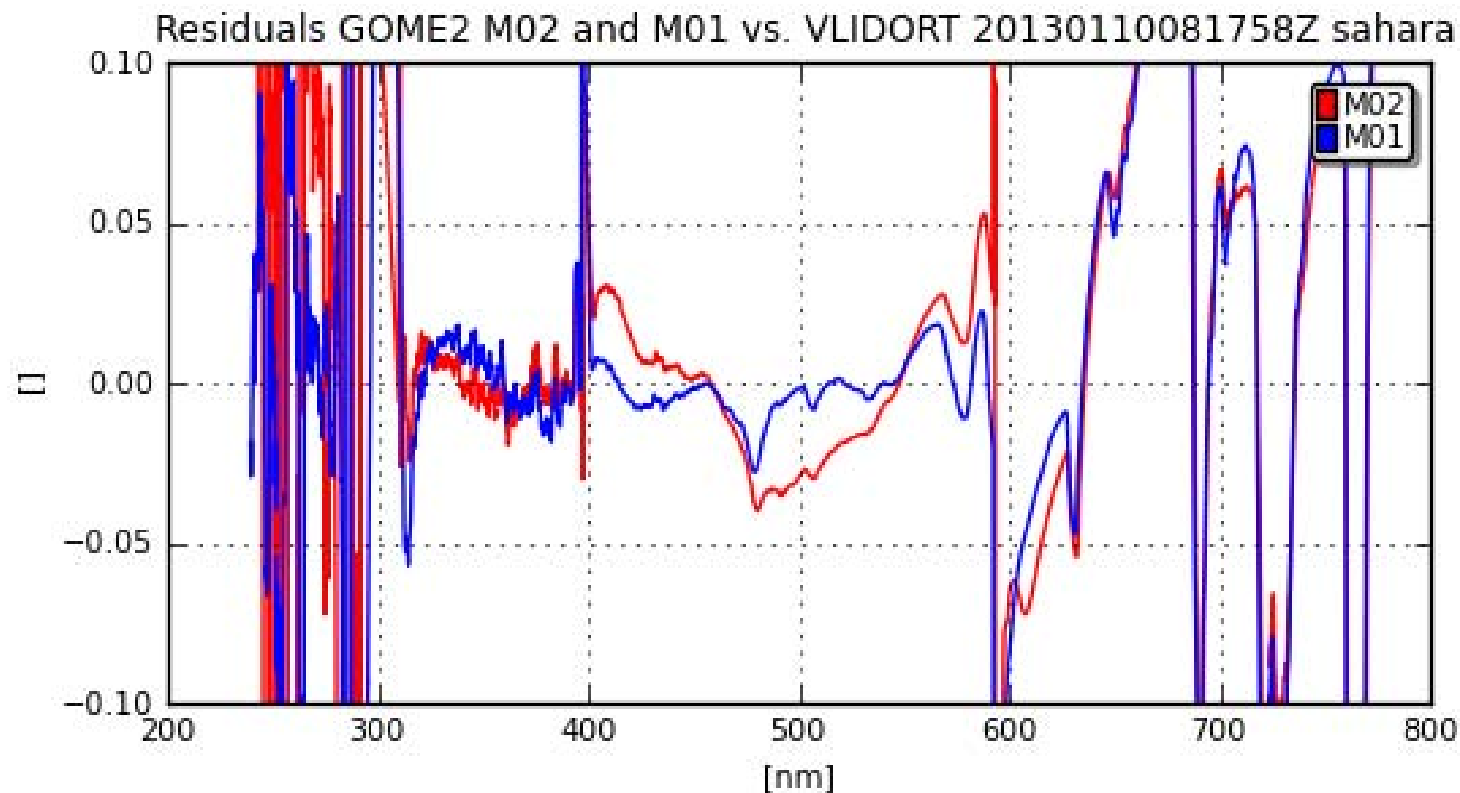

Metop-A/B GOME-2 inter-calibration

Earthshine co-located Metop-A/B residuals /
Interpretation with forward model – V-LIDORT

GOME-2 FM3
Metop-A

GOME-2 FM2
Metop-B

Residual Metop-B with V-LIDORT
Residual Metop-A with V-LIDORT

**Residuals between Metop-A and
Metop-B**

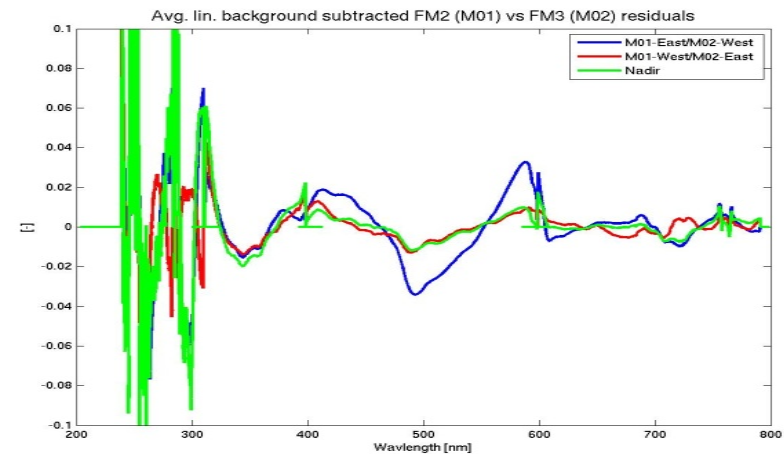
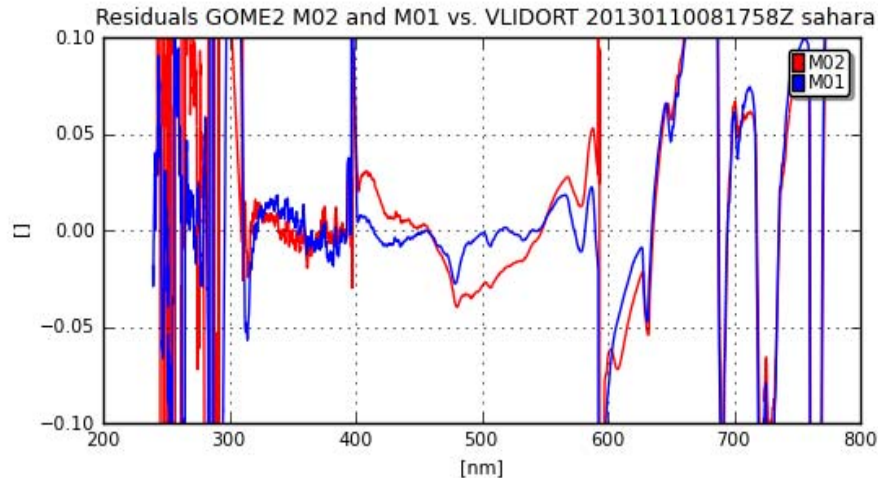

- **Broad-band structure in Metop-A channel 3**
- **Small-scale structures in Metop-B channel 3**

Metop-A/B GOME-2 Radiometric accuracy and calibration

Earthshine co-located Metop-A/B residuals / Background-subtracted plus degradation residual from Metop-A

GOME-2 FM3
Metop-A

GOME-2 FM2
Metop-B

Lin. background subtracted FM2 (M01) vs FM3 (M02) avg. residual for Sahara box 20121225084918

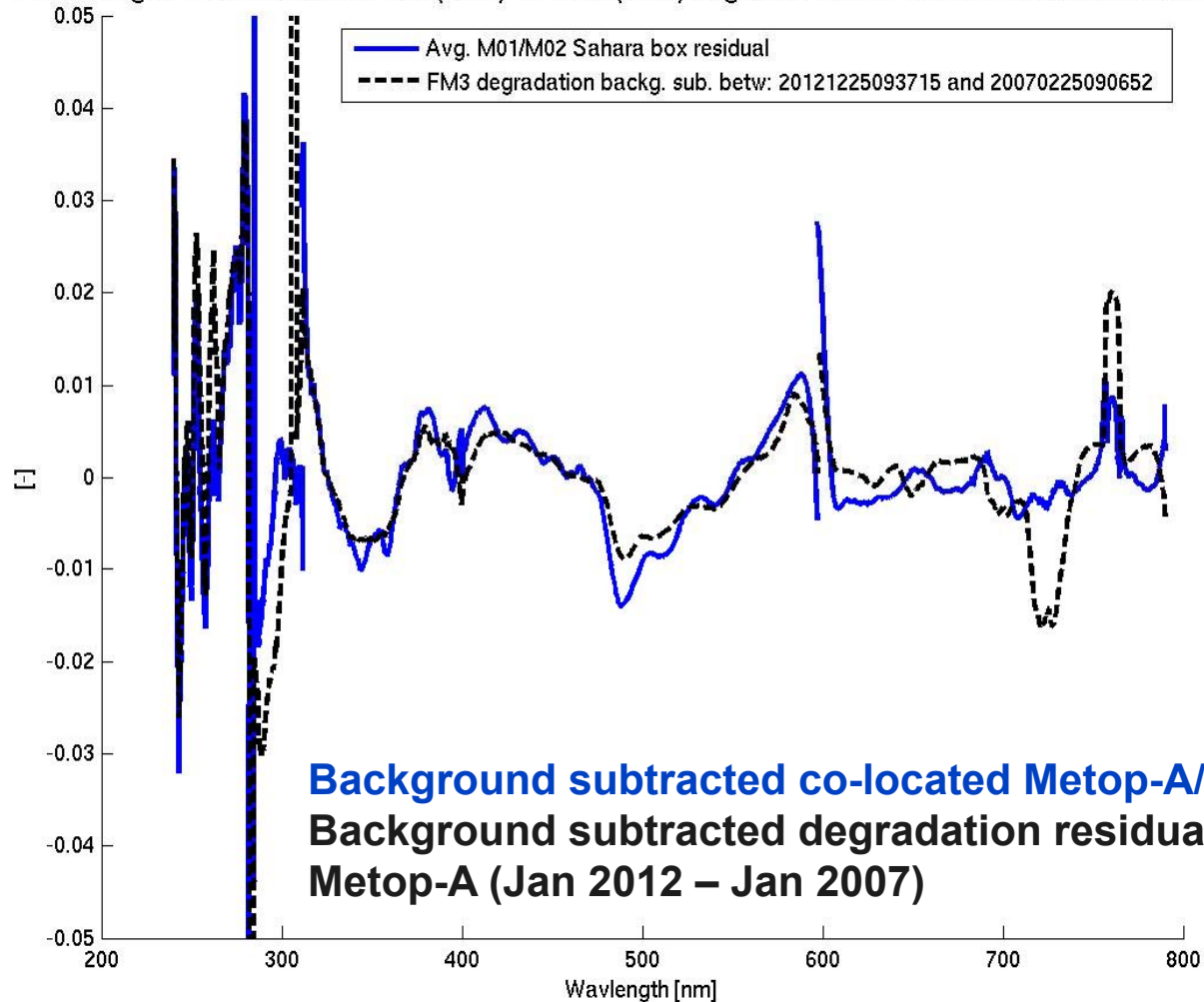

Metop-A/B GOME-2 inter-calibration

Earthshine co-located Metop-A/B residuals / Background-subtracted plus degradation residual from Metop-A subtracted

GOME-2 FM3
Metop-A

GOME-2 FM2
Metop-B

FM3 degradation subtracted FM2 (M01) vs FM3 (M02) avg. residual for Sahara box 20121225084918

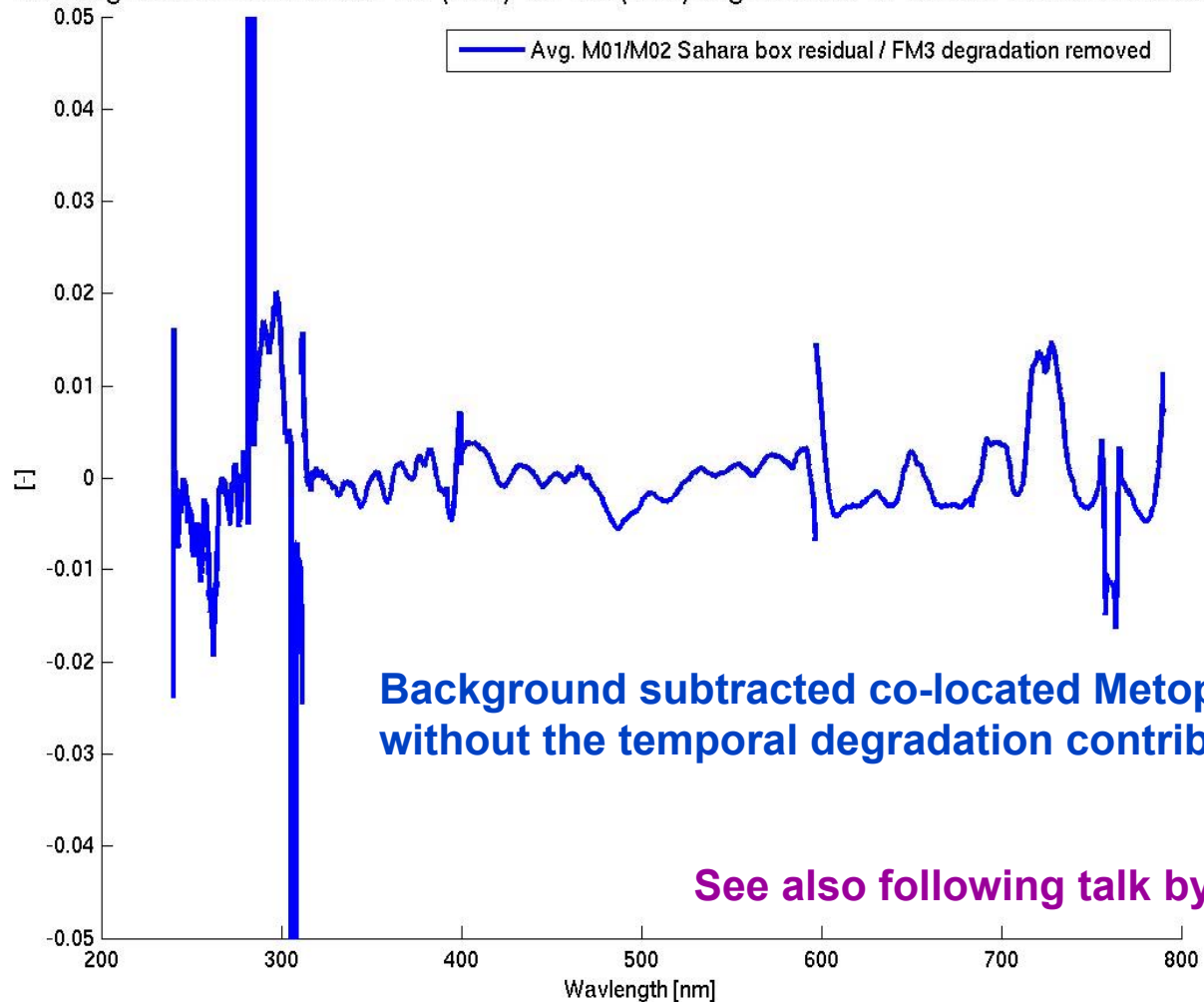

Background subtracted co-located Metop-A/B residual without the temporal degradation contribution of Metop-A

See also following talk by X. Wu et al

Metop-A/B GOME-2 inter-calibration

Earthshine co-located Metop-A/B residuals / Background-subtracted plus degradation residual from Metop-A subtracted

GOME-2 FM3
Metop-A

GOME-2 FM2
Metop-B

After subtracting GOME-2 /MetopA long-term degradation residuals most of the remainder in the spectral structure can be associated to GOME-2 / Metop-B

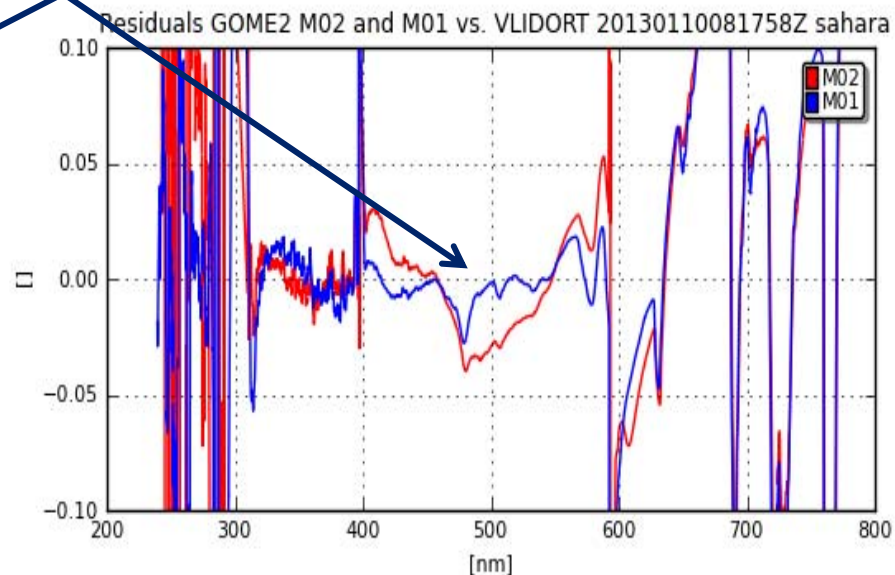
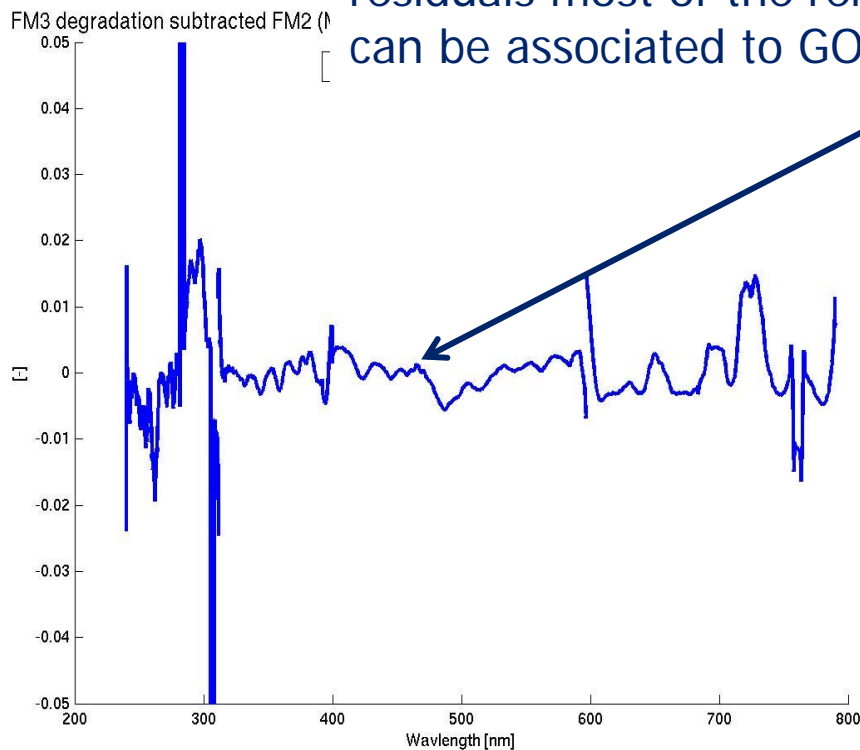

➤ **Metop-B spectral structures will be addressed in forthcoming processor version 6.1.0 (June 2015)**

Metop-A/B GOME-2 / OMPS

Wu et al., JGR, 2014

GOME-2 FM3
Metop-A

GOME-2 FM2
Metop-B

NPP/Metop-A/B SNRs

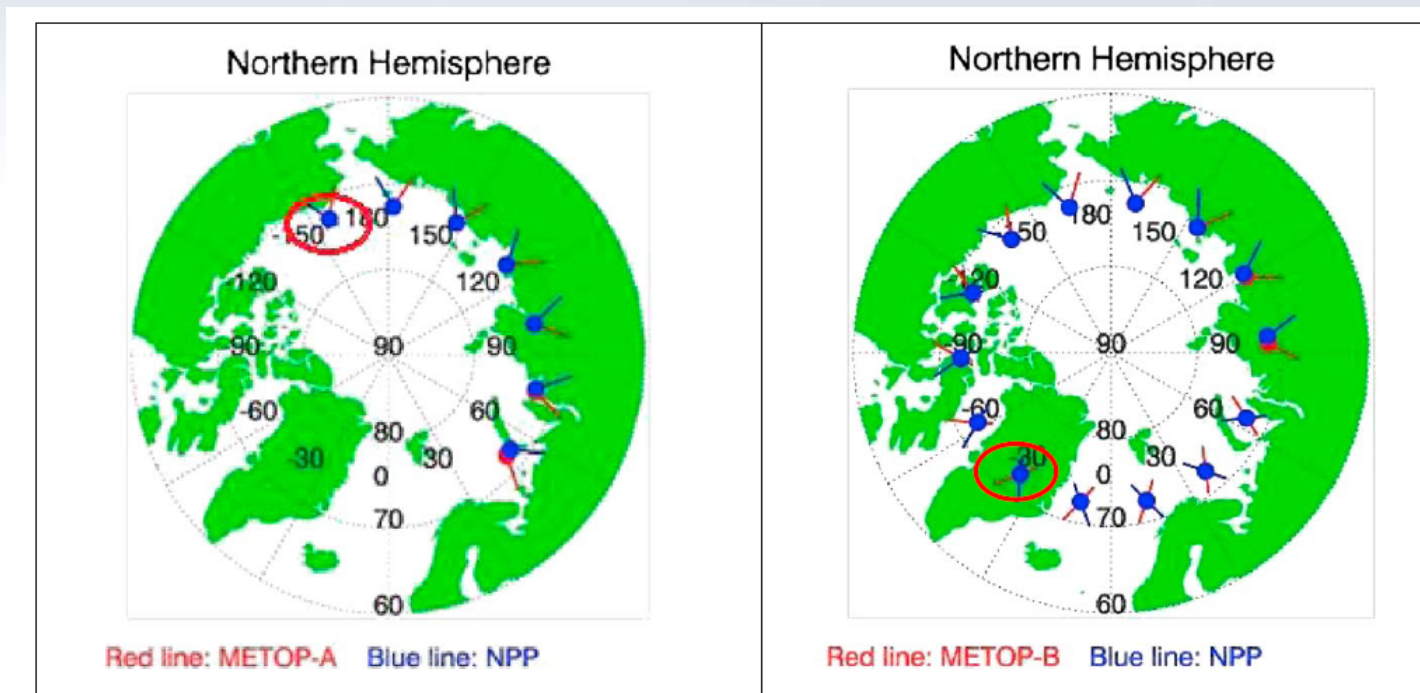

Courtesy Wu et al., JGR, 2014, NOAA/NESDIS

Metop-A/B GOME-2 / OMPS

Wu et al, JGR 2014

GOME-2 FM3
Metop-A

GOME-2 FM2
Metop-B

GOME-2 Metop-A VS OMPS

GOME-2 Metop-B VS OMPS

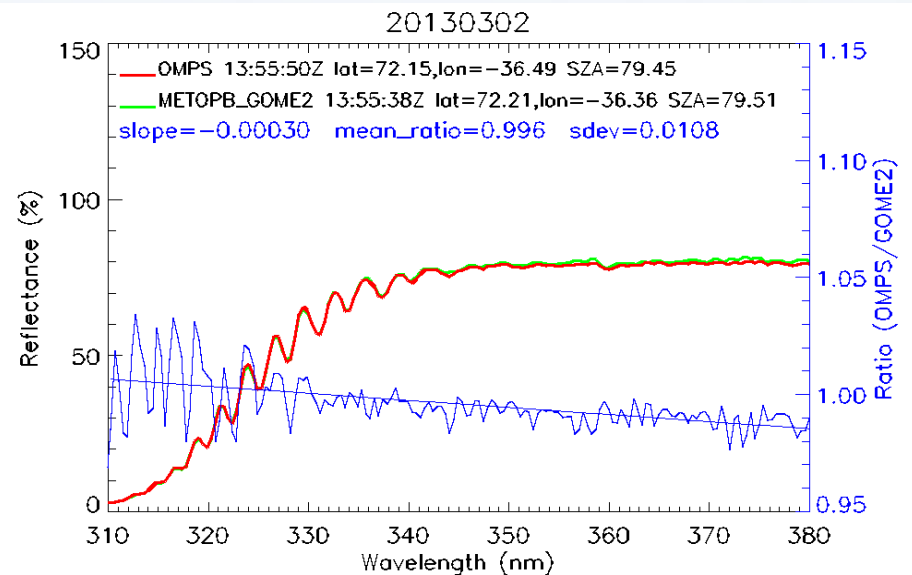
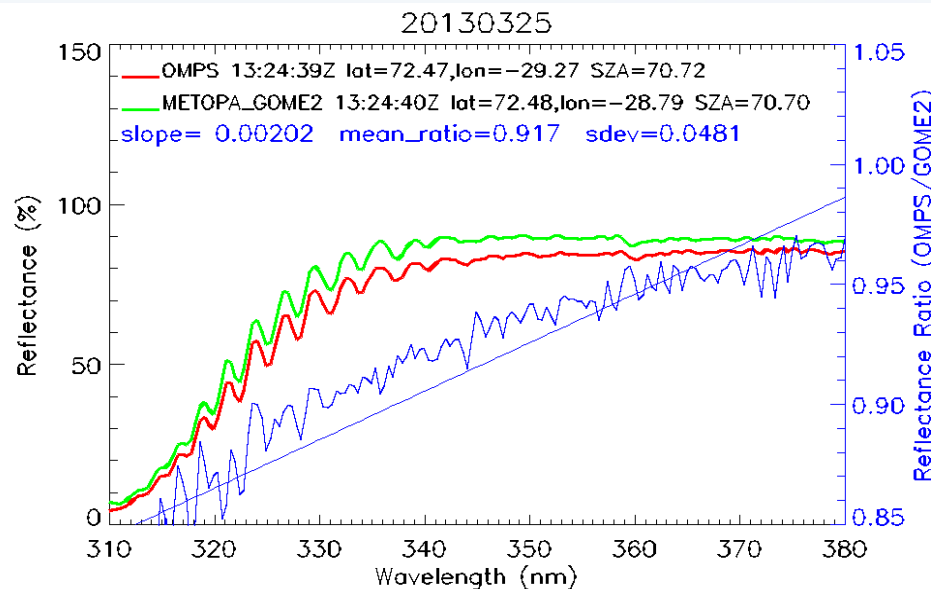

Courtesy Wu et al., JGR, 2014, NOAA/NESDIS
Data from March 2013

GOME-2/AVHRR reflectivity inter-calibration

AVHRR ch 1/ Metop-A

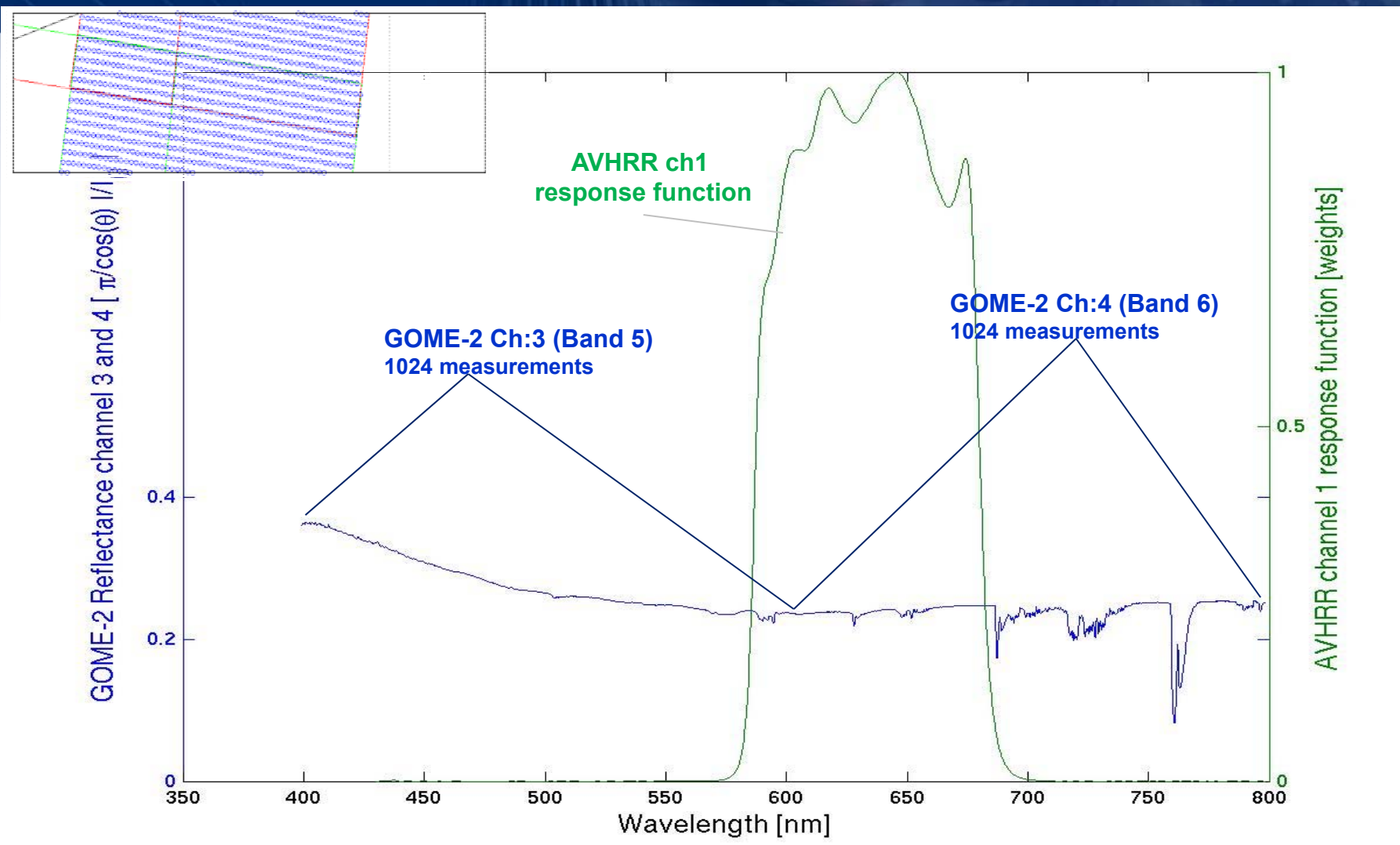

GOME-2 / AVHRR reflectivity inter-calibration

AVHRR ch 1/ Metop-A

GOME-2 FM3
Metop-A

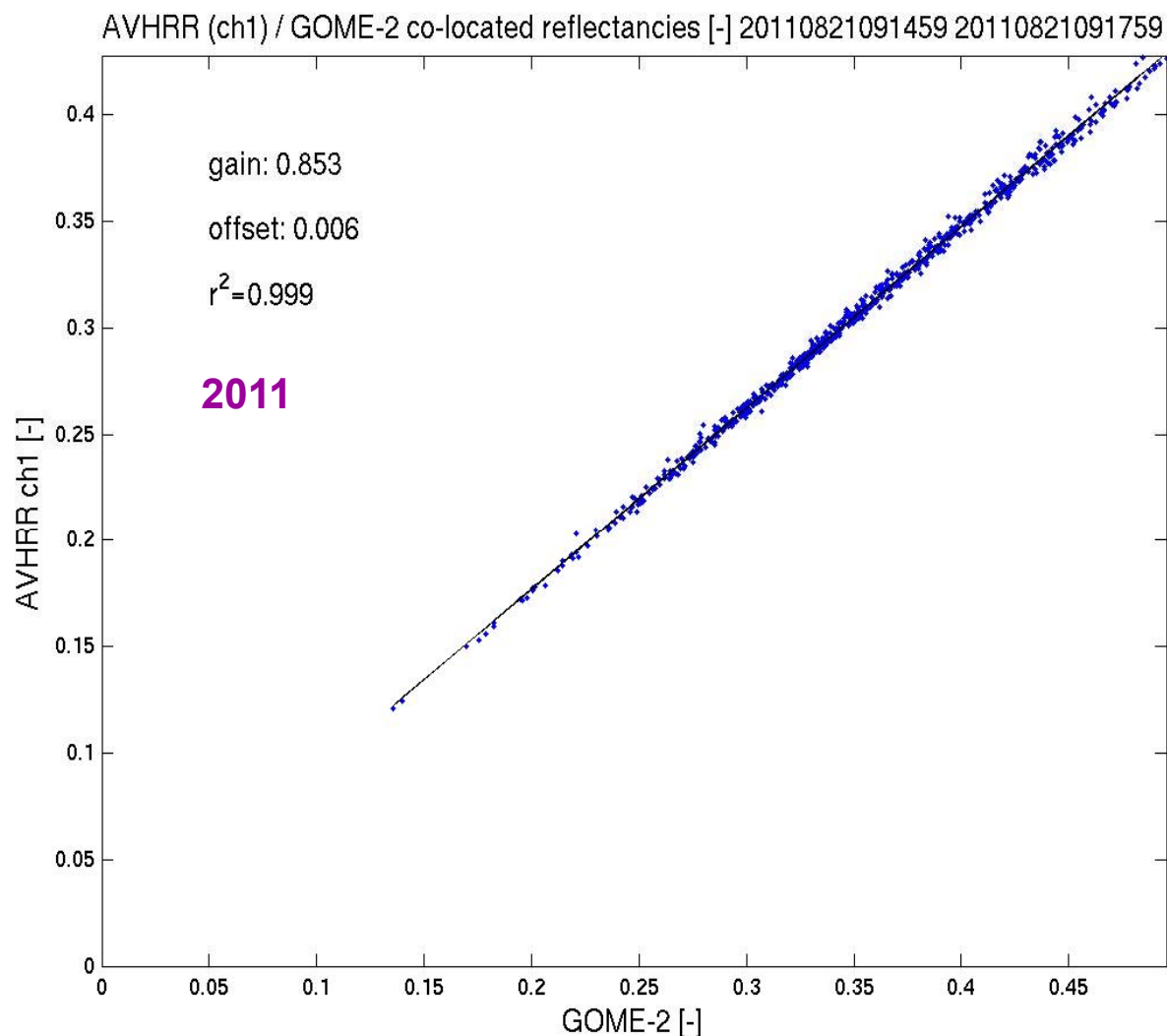

**AVHRR channel 1 to
GOME-2/Metop-A gain
in reflectivity ~10%
(AVHRR < GOME-2)**

**Results indicate that
the gain has been
quite stable from
2007 to 2011.**

see *GSICS Quarterly
Newsletters*, vol 5, number 3,
Latter et al.

*spatial aliasing
accounted for*

GOME-2 / AVHRR reflectivity inter-calibration

AVHRR ch 1/ Metop-A

GOME-2 FM3
Metop-A

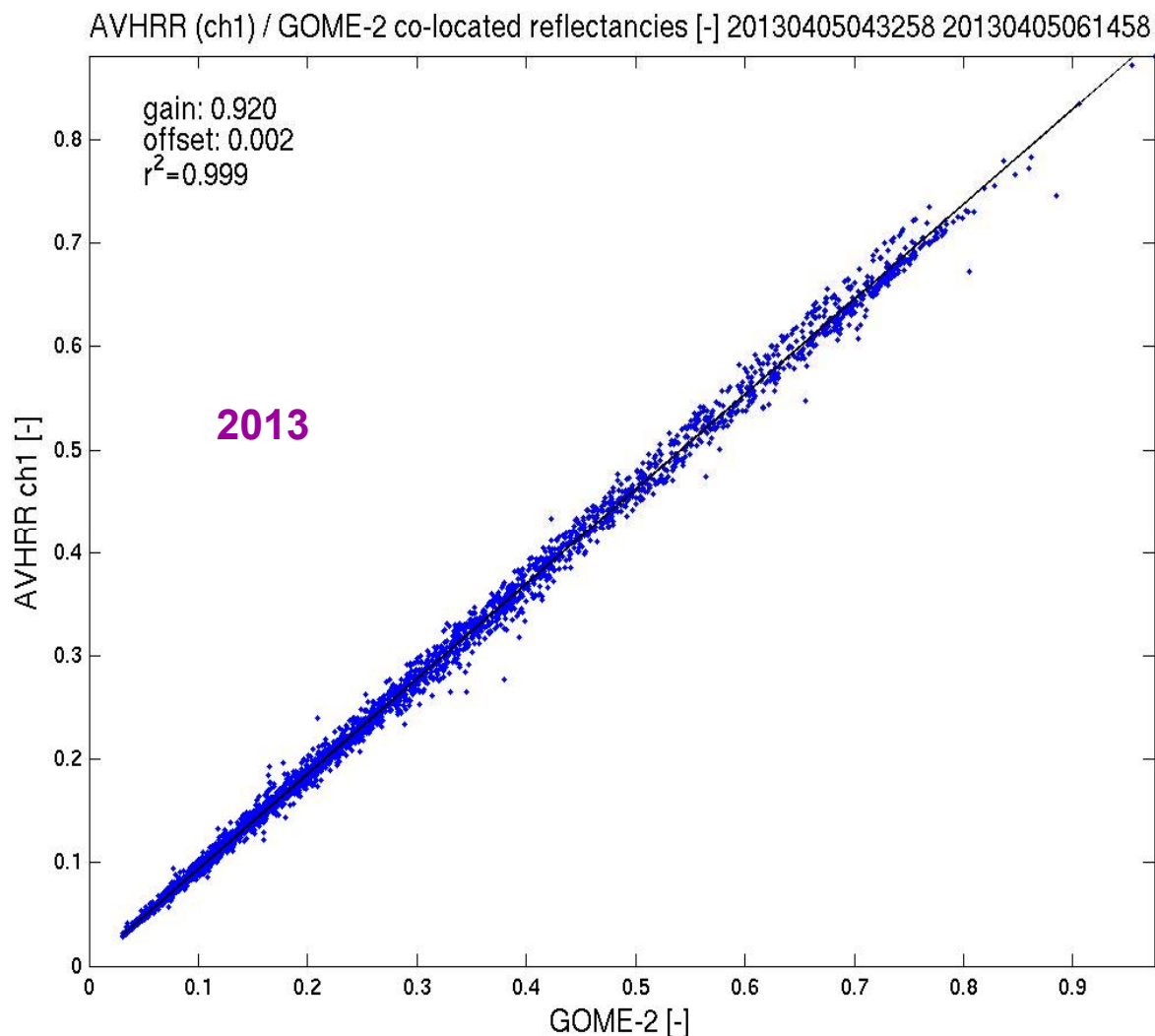

AVHRR channel 1 to
GOME-2/Metop-A gain
in reflectivity <8%
(AVHRR < GOME-2)

2011 - 2013

see GSICS Quarterly
Newsletters, vol 5, number 3,
Latter et al.

*spatial aliasing
accounted for*

GOME-2 Metop-A degradation component modelling

Sahara – Reflectivity Degradation / AVHRR ch1-domain

GOME-2 FM3
Metop-A

R2 campaign
Jan 2007– Jan 2012
OPS phase (same PPF 5.3)
Jan 2012 – Oct 2013

Reflectivity Degradation

600 nm
640 nm
680 nm

*Average over all
GOME-2 viewing
angles*

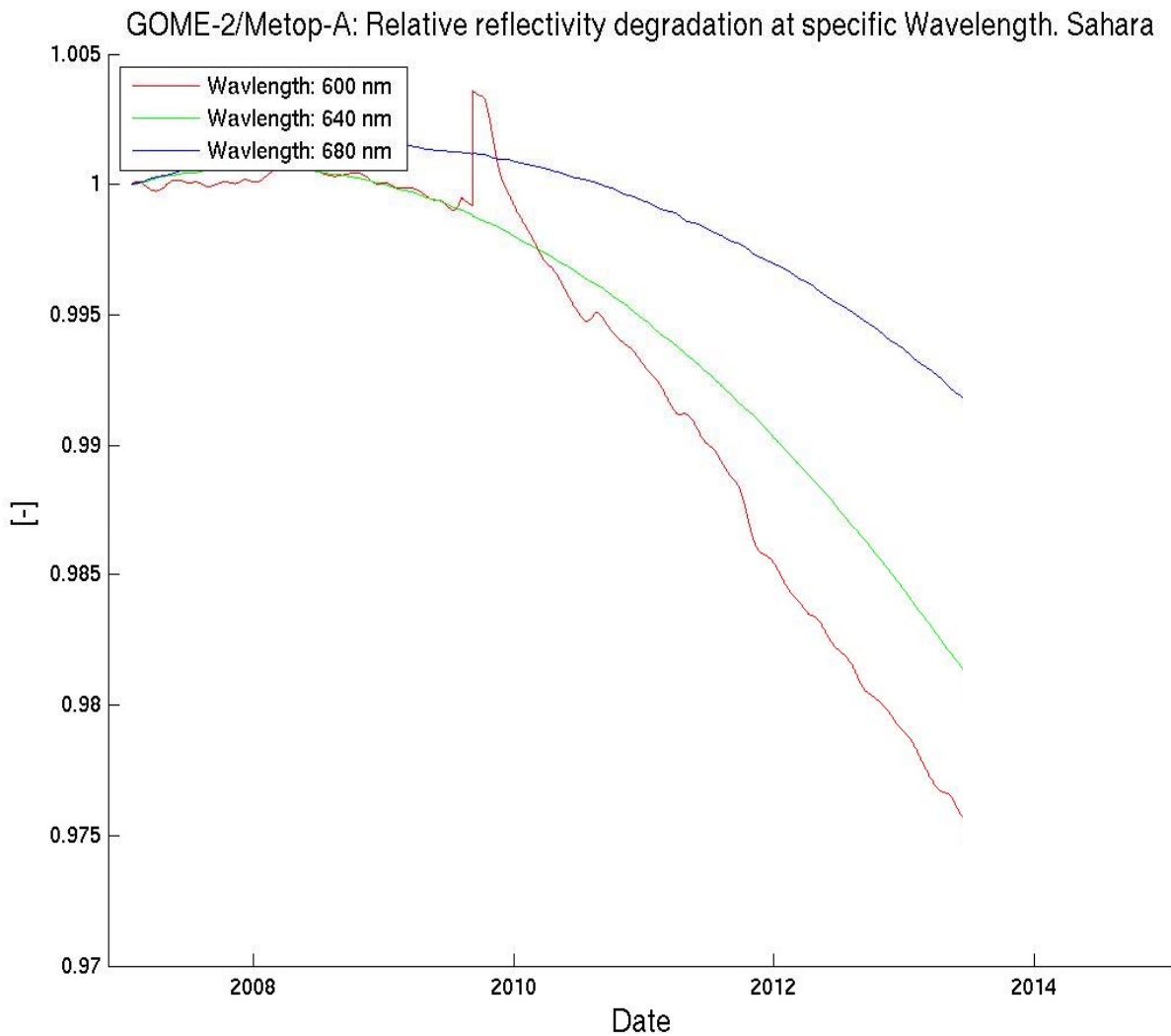

GOME-2/AVHRR reflectivity inter-calibration

AVHRR ch 1 / Metop-A

GOME-2 FM3
Metop-A

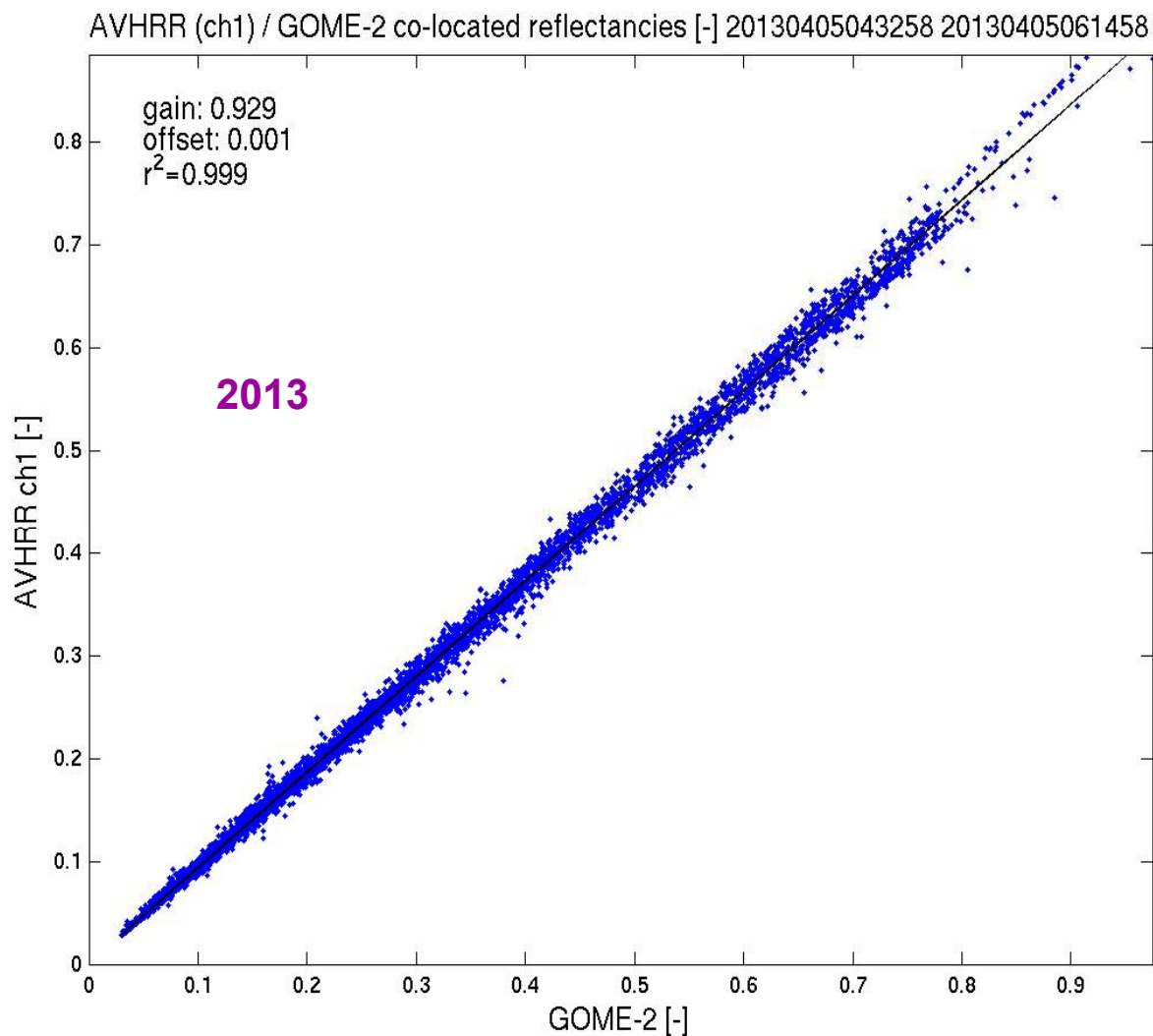

AVHRR channel 1 to
GOME-2/Metop-A gain
in reflectivity <8%
(AVHRR < GOME-2)

2013
Corrected /
Un-corrected

see GSICS Quarterly
Newsletters, vol 5, number 3,
Latter et al.

*spatial aliasing
accounted for*



GOME-2/AVHRR reflectivity inter-calibration

AVHRR ch 1 / Metop-A

GOME-2 FM3
Metop-A

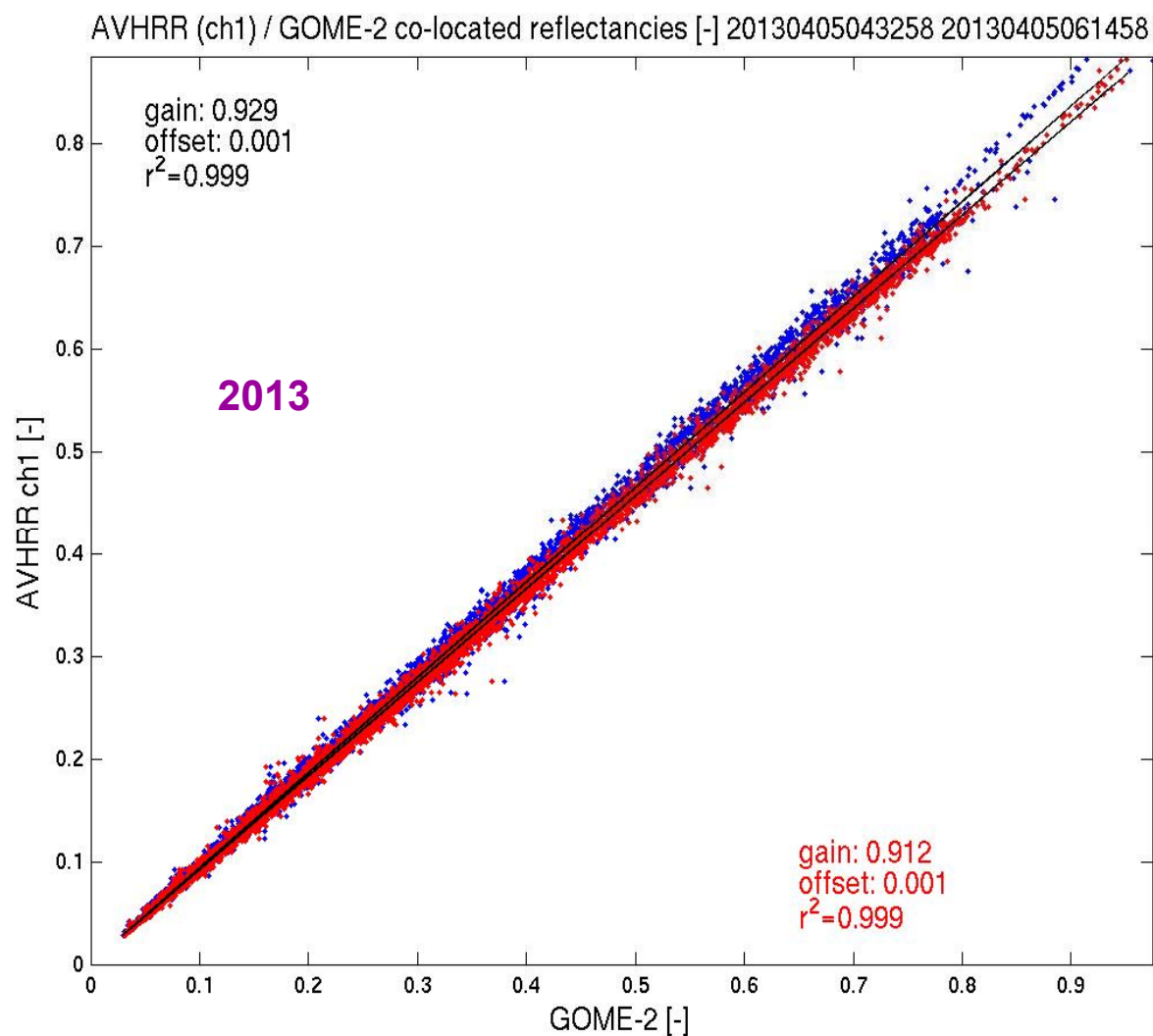

AVHRR channel 1 to
GOME-2/Metop-A gain
in reflectivity <8%
(AVHRR < GOME-2)

2013
Corrected /
Un-corrected

see GSICS Quarterly
Newsletters, vol 5, number 3,
Latter et al.

*spatial aliasing
accounted for*



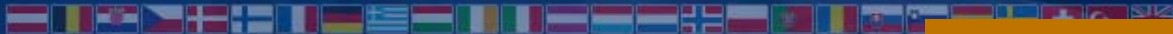

GOME-2 / Seviri reflectivity inter-calibration

GOME-2 FM3
Metop-A

SEVIRI ch1/ MSG-2 – preliminary results

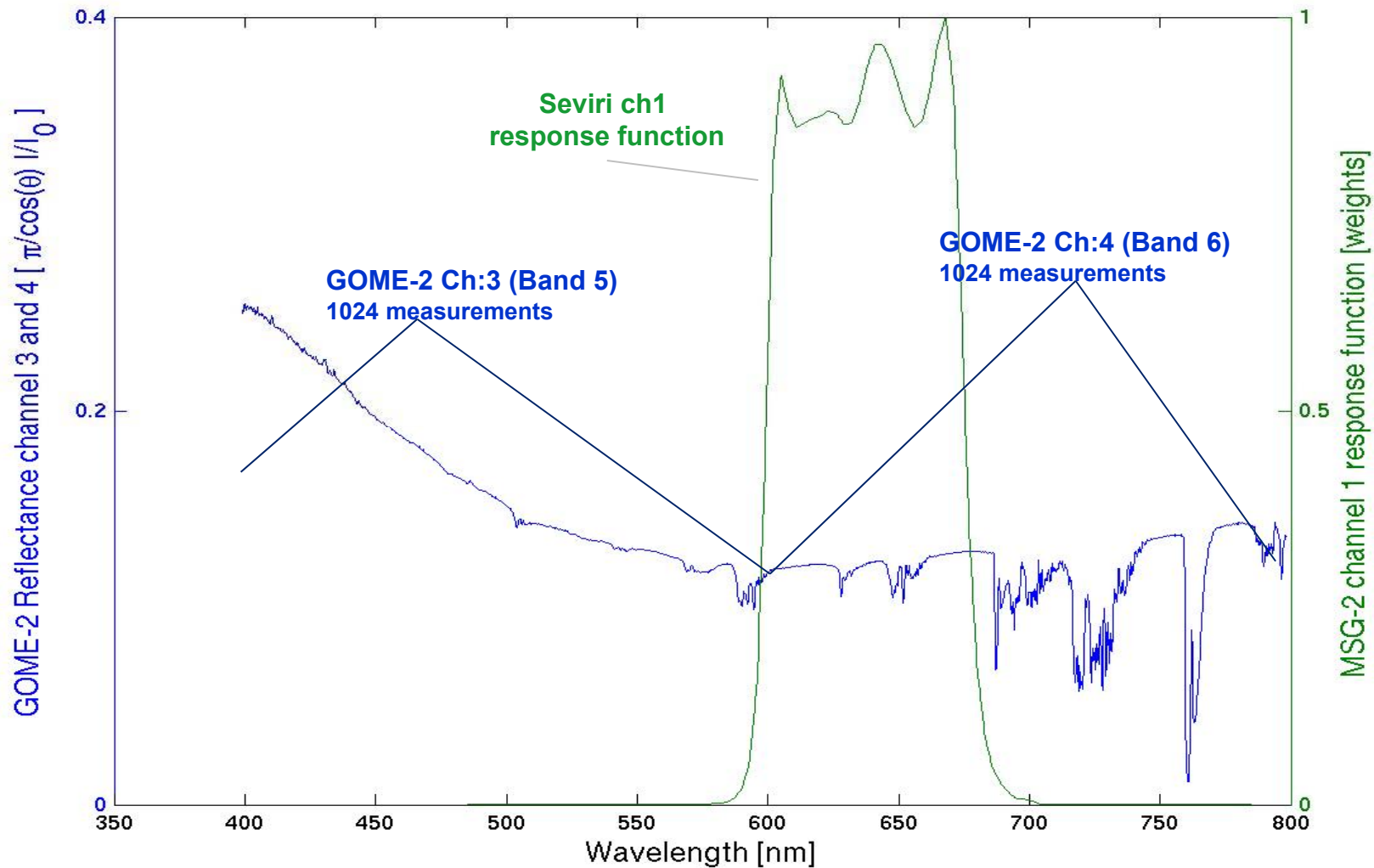

GOME-2 / Seviri reflectivity inter-calibration

SEVIRI ch1/ MSG-2 – preliminary results

GOME-2 FM3
Metop-A

GOME2--MSG reflectancies vis0.6 channel [%] 20110728050255 20110728150255

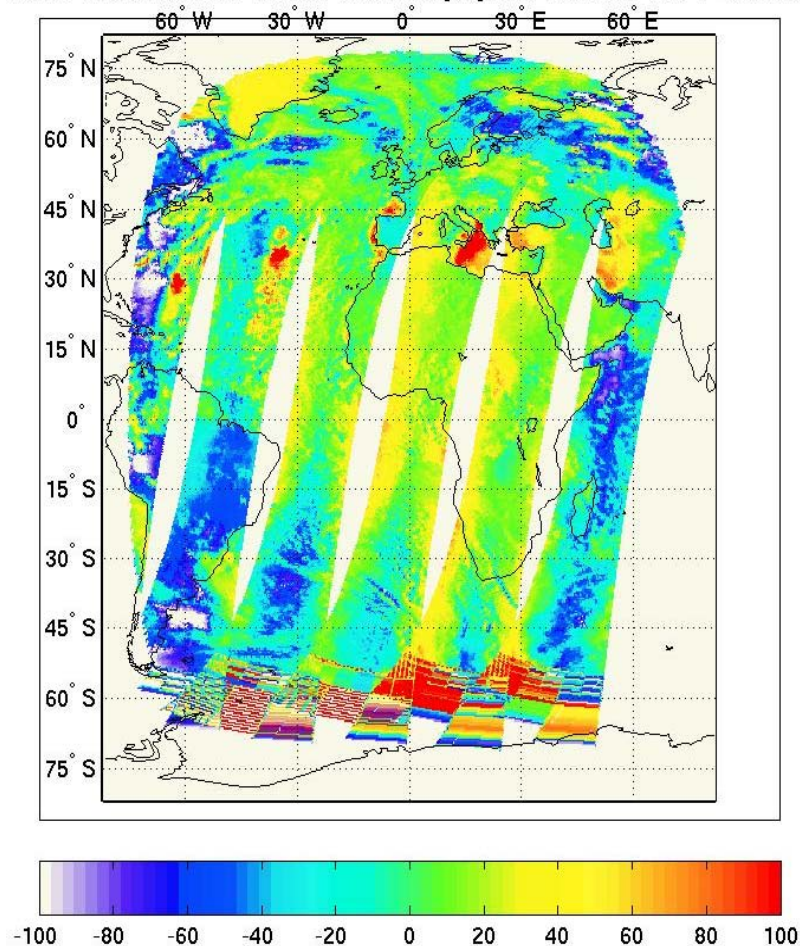

**Co-location of GOME-2
Metop-A with Seviri / MSG
data.**

**Spatial collocation:
Average of all Seviri
measurements (~4km) in
one GOME-2 ground pixel
(40 by 80 km)**

**Temporal collocation:
Within +/- 15 min of
sensing time.**

*No spatial aliasing
correction*

GOME-2/Metop-B reflectivity inter-calibration

SEVIRI ch1/ MSG-3 – preliminary results



GOME-2 FM2
Metop-B

GOME2 M01--MSG3 reflectancies vis0.6 channel [%] 20130107092843 20131122093043

MSG3 vis0.6 reflectancies co

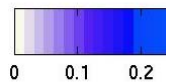
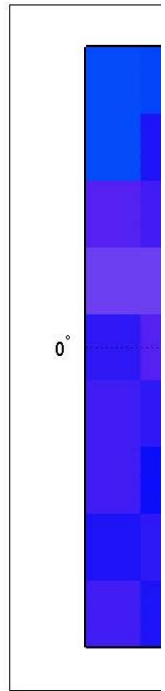

Reflect
1.5/1

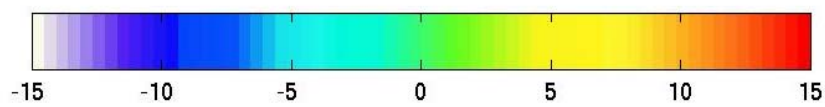
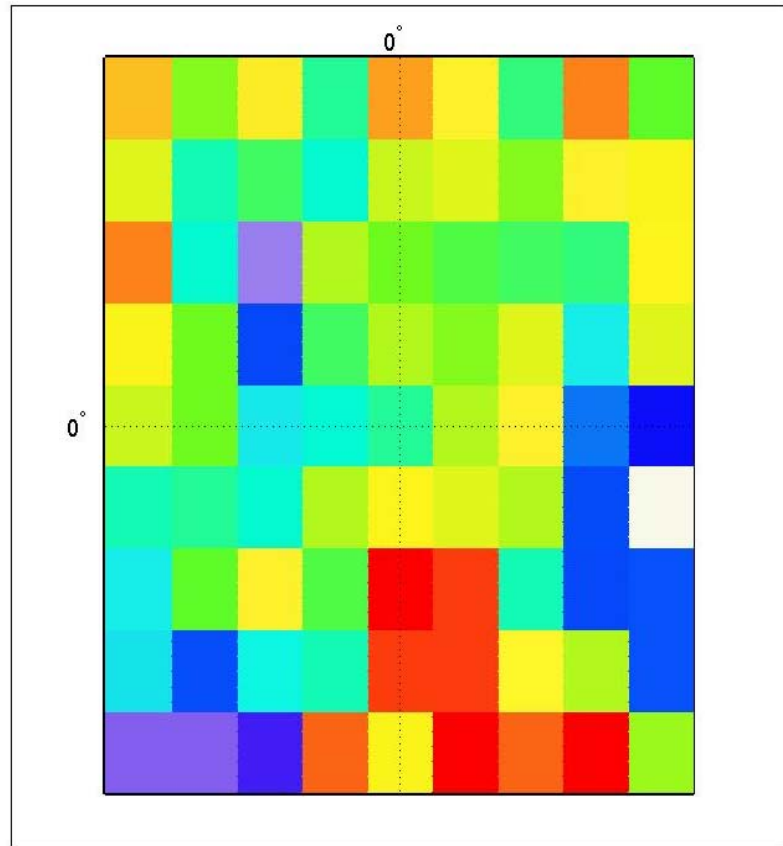

Residual MSG-3 /Seviri vs GOME-2 / Metop-B [%]
1.5/1.5 degrees box at 0/0°

107092843 20131122093043

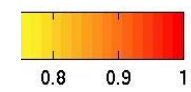
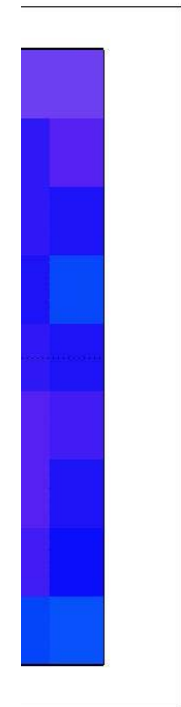

/ Metop-B
at 0/0°



GOME-2/Seviri reflectivity inter-calibration

SEVIRI ch1/ MSG-3 vs GOME-2/Metop-B – preliminary results

GOME-2 FM2
Metop-B

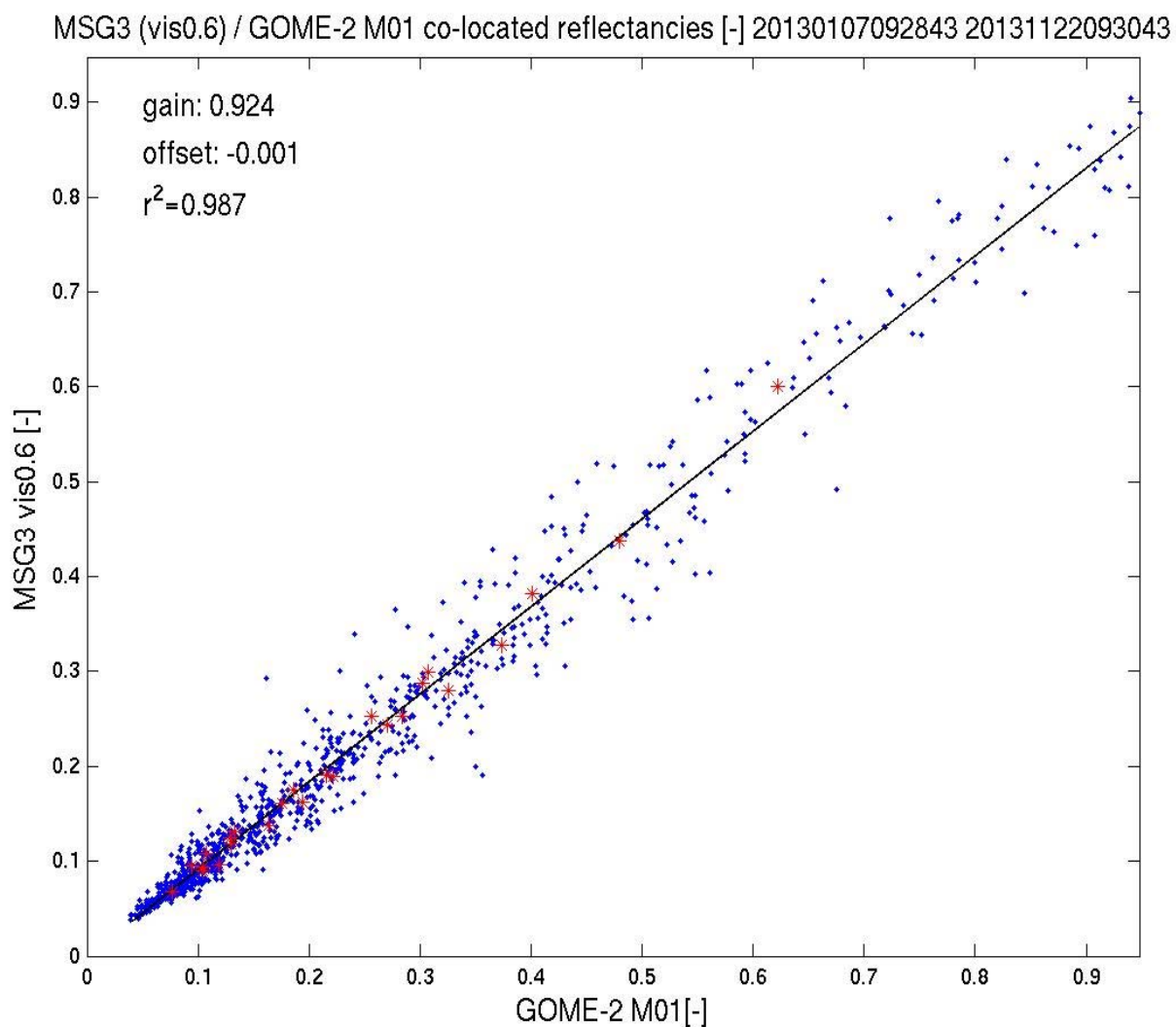

**MSG-3 / Seviri ch 1 to
GOME-2/Metop-B
gain in reflectivity
~8%
(Seviri < GOME-2)**

**1st Jan to 22nd Nov
2013**

*** bi-weekly average**



GOME-2 pointing and Geo-referencing

Forward and Back-scan – spatial aliasing / preliminary results!

GOME-2 FM3
Metop-A

GOME-2 FM2
Metop-B

GOME-2 scanning: forward scan nadir viewing pixel

Using accumulated AVHRR channel 1 radiances, convolved with spectral response function within reported geo-location of one GOME-2 ground pixel

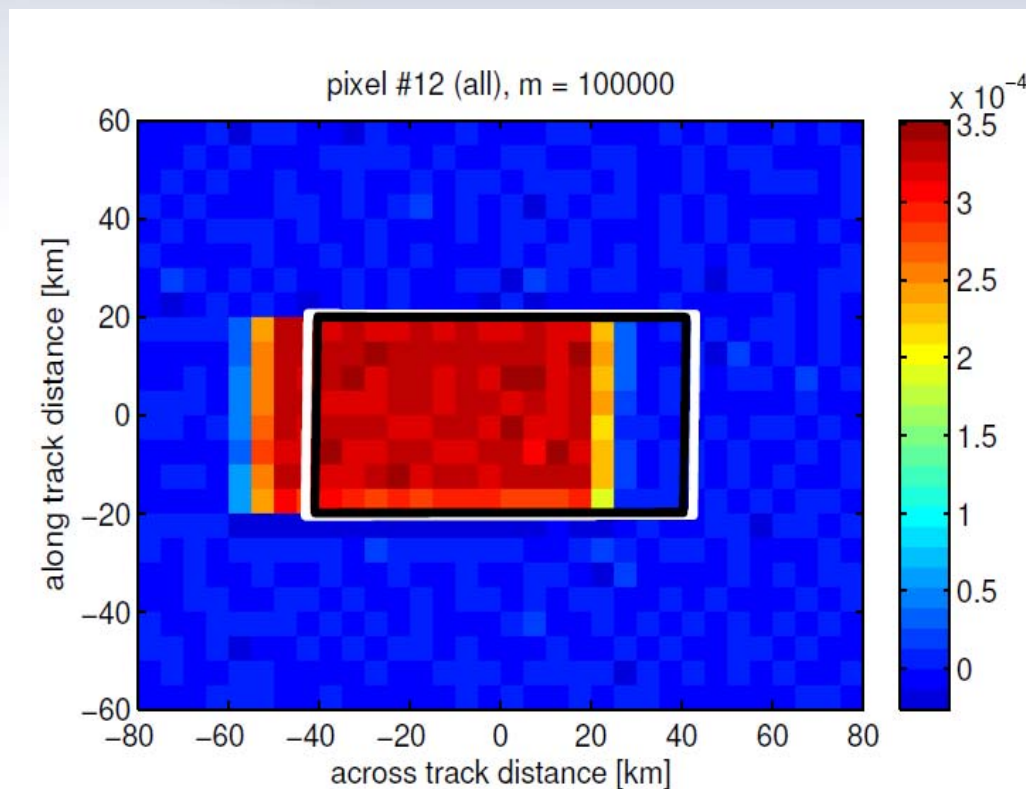

Plot shows:

- Area of highest correlation (colored)
- Geo-reference footprint of one pixel as reported in GOME-2 level-1 product (black square)



GOME-2 pointing and Geo-referencing

Forward and Back-scan – spatial aliasing / preliminary results!

GOME-2 FM3
Metop-A

GOME-2 FM2
Metop-B

GOME-2 scanning:

forward scan nadir viewing pixel

Using accumulated AVHRR channel 1 radiances, convolved with spectral response function within reported geo-location of one GOME-2 ground pixel

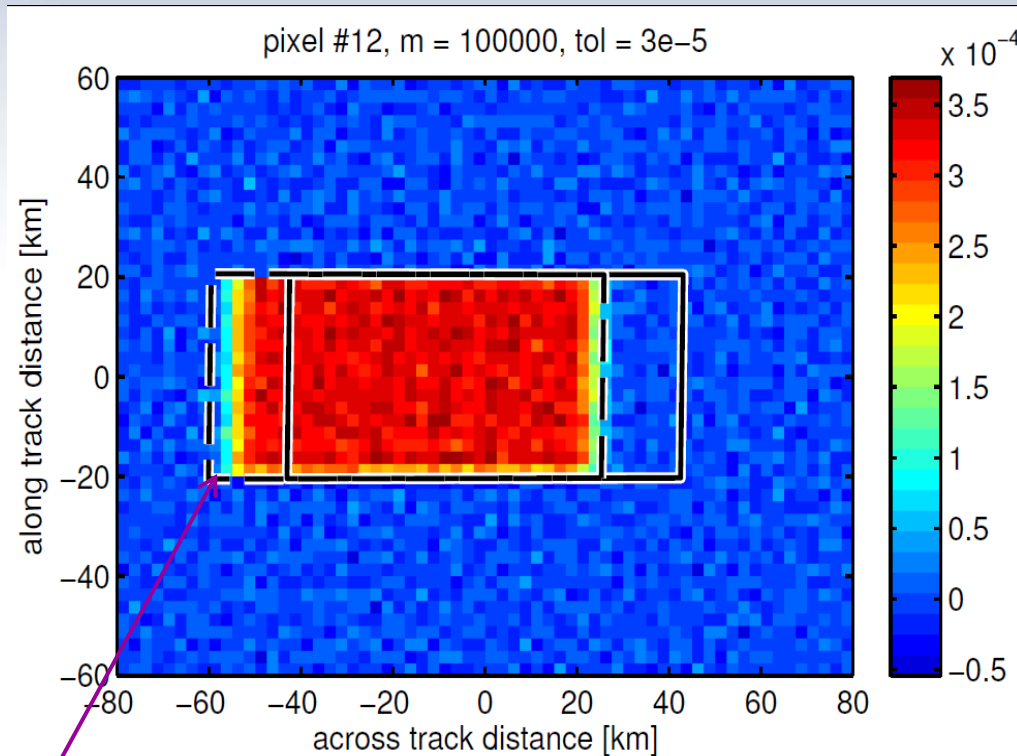

- Plot shows:*
- Area of highest correlation (colored)
 - Geo-reference footprint of one pixel as reported in GOME-2 level-1 product (black square)

Corrected according to detector read-out timing: *spatial aliasing*

Courtesy: H. Sihler, *MPIC, Mainz*

11th CEOS-ACC, Frascati, 2015

Slide: 28



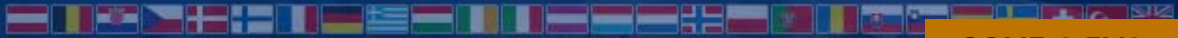

GOME-2 pointing and Geo-referencing Forward and Back-scan – spatial aliasing / preliminary results!

GOME-2 FM3
Metop-A

GOME-2 FM2
Metop-B

Using accumulated AVHRR channel 1 radiances, convolved with spectral response function within reported geo-location of one GOME-2 ground pixel

pixel 23 – western swath edge

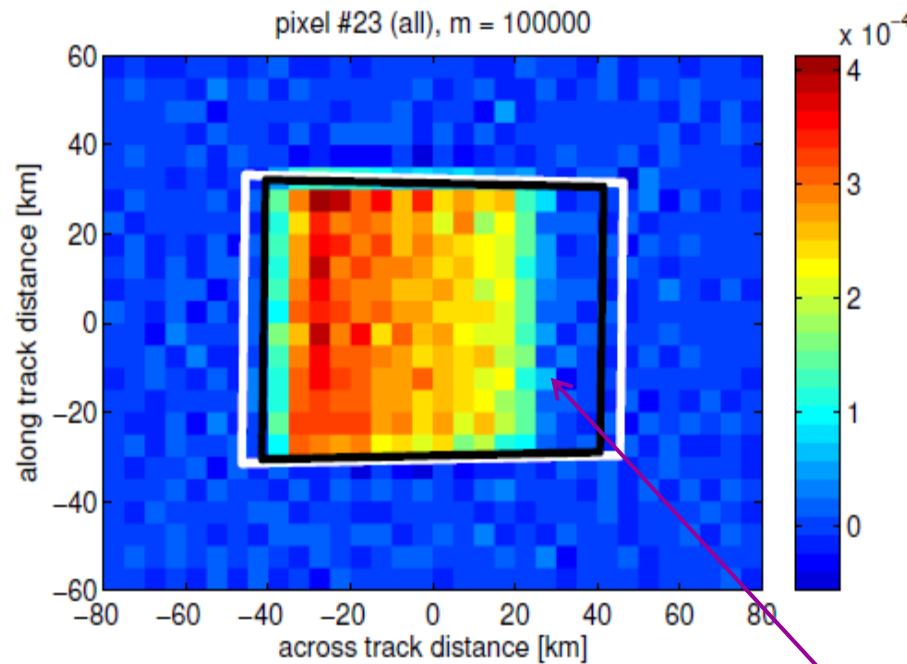

Plot shows:

- Area of highest correlation (colored)
- Geo-reference footprint of one pixel as reported in GOME-2 level-1 product (black square)

Distorted (squeezed) Western pixel because of scan mirror turn during detector read-out

Courtesy: H. Sihler, *MPIC, Mainz*

11th CEOS-ACC, Frascati, 2015

Slide: 29



ISRF in-orbit monitoring – FM2/FM3

FWHM FM2/FM3 from on-board spectral light source – Long-term stability in

GOME-2 FM3
Metop-A

GOME-2 FM2
Metop-B

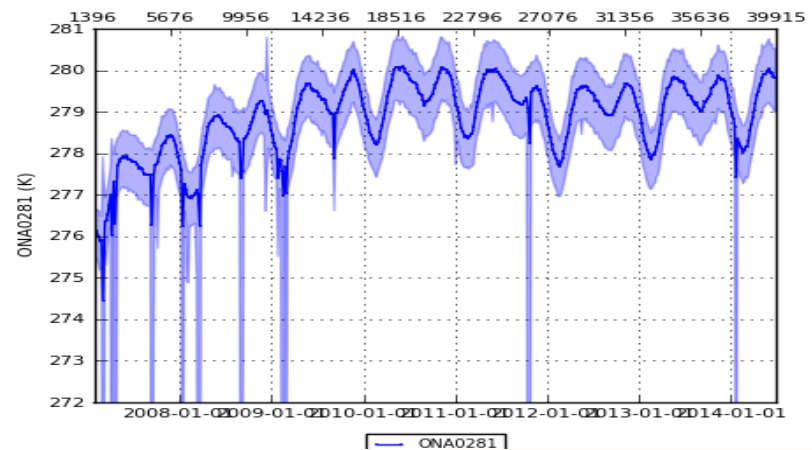
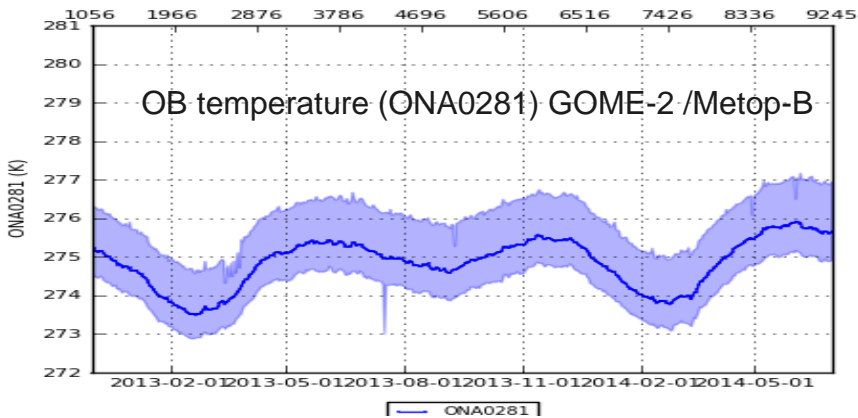
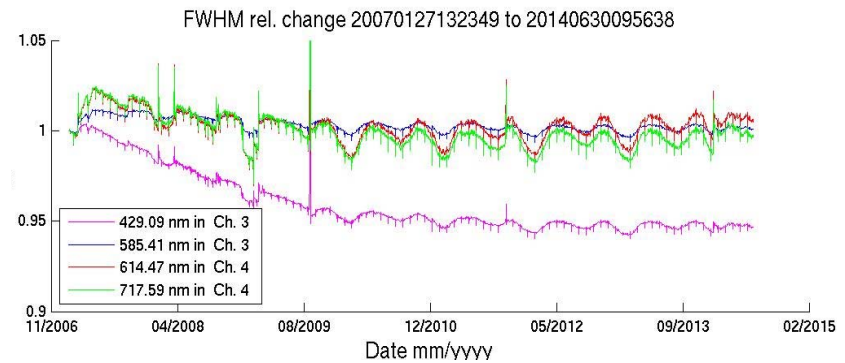
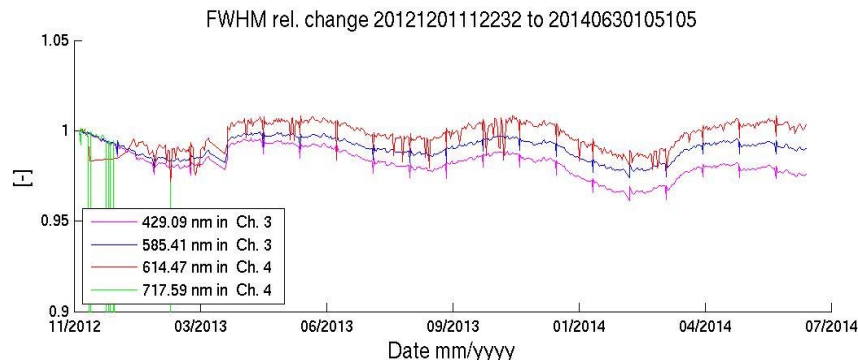
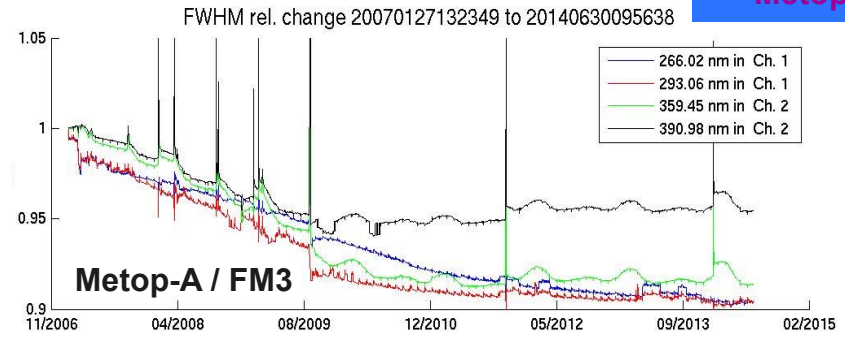
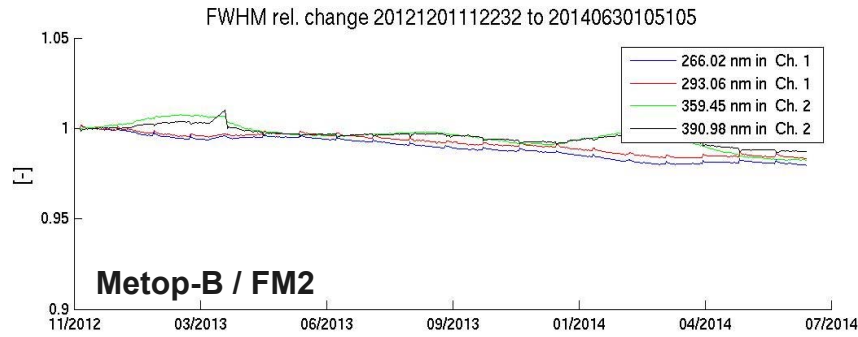

Goniometry: Angular dependence for Solar Measurements (AIRR)

Comparison between current key-data and high res. **elevation** angle grid

GOME-2 FM3
Metop-A

The Angular dependence of irradiance on the diffuser in elevation and solar azimuth $I_0(\phi, e)$ is

- difficult to measure on-ground (long-measurement period / in vacuum)
- but one can derive it from in-flight data
- 1 year of in-flight data needed

Of relevance also for other current and future missions!

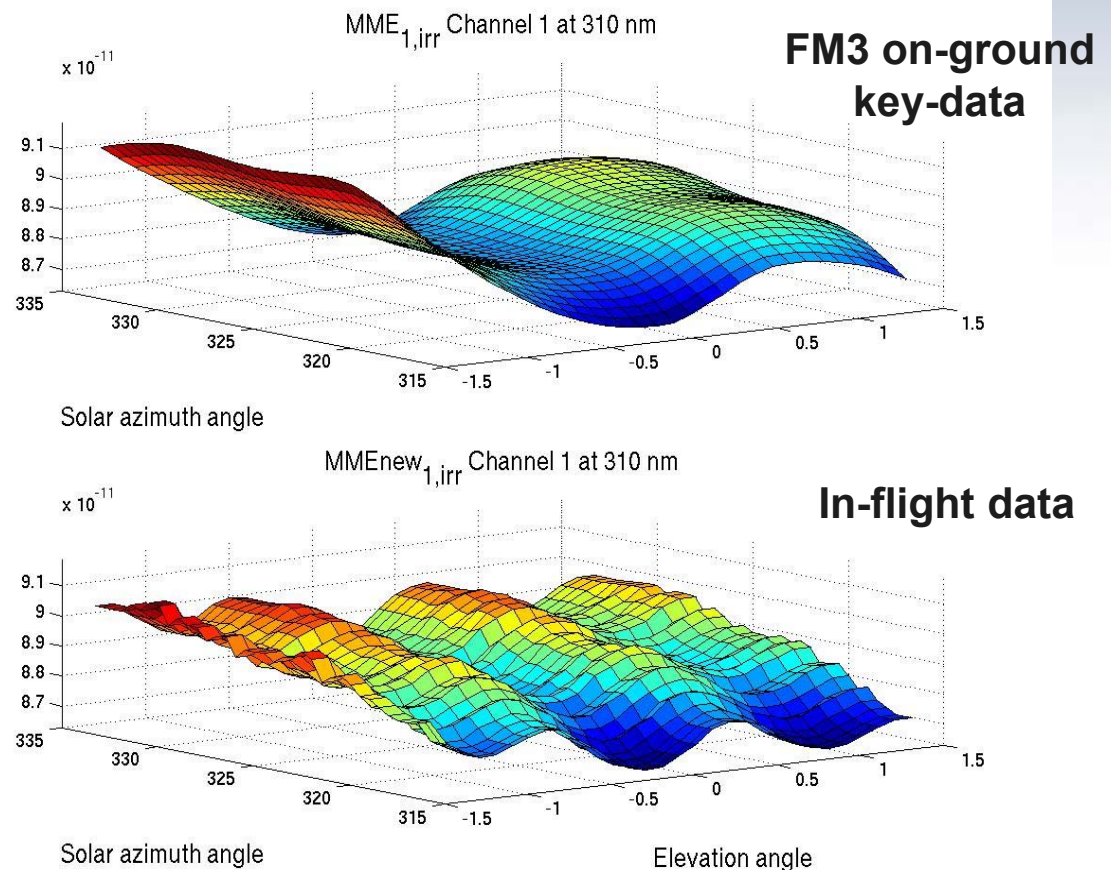

Goniometry: Angular dependence for Solar Measurements (AIRR)

Application of in-orbit derived slit-function
745 nm

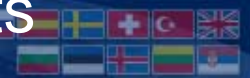

GOME-2 FM3
Metop-A

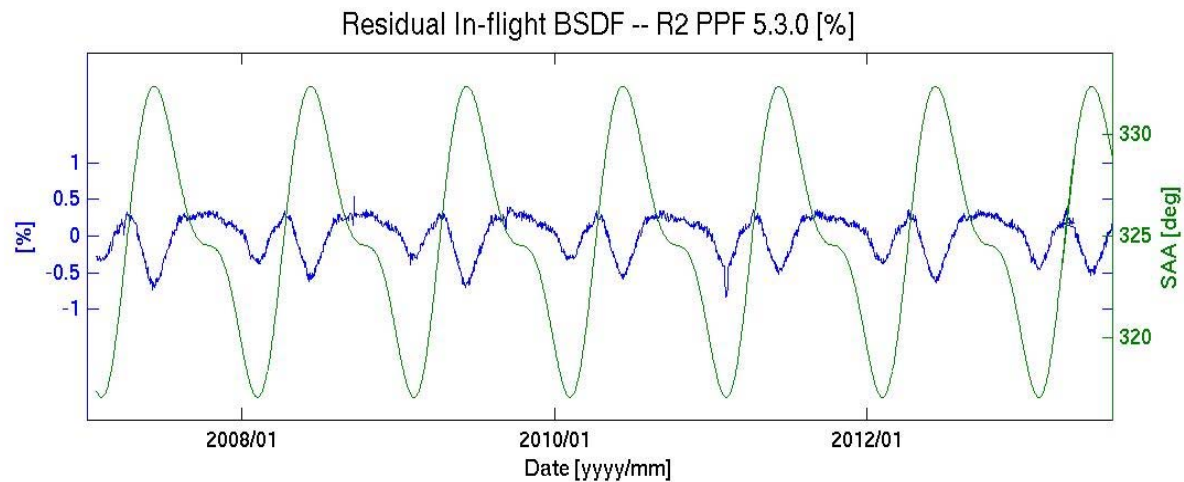
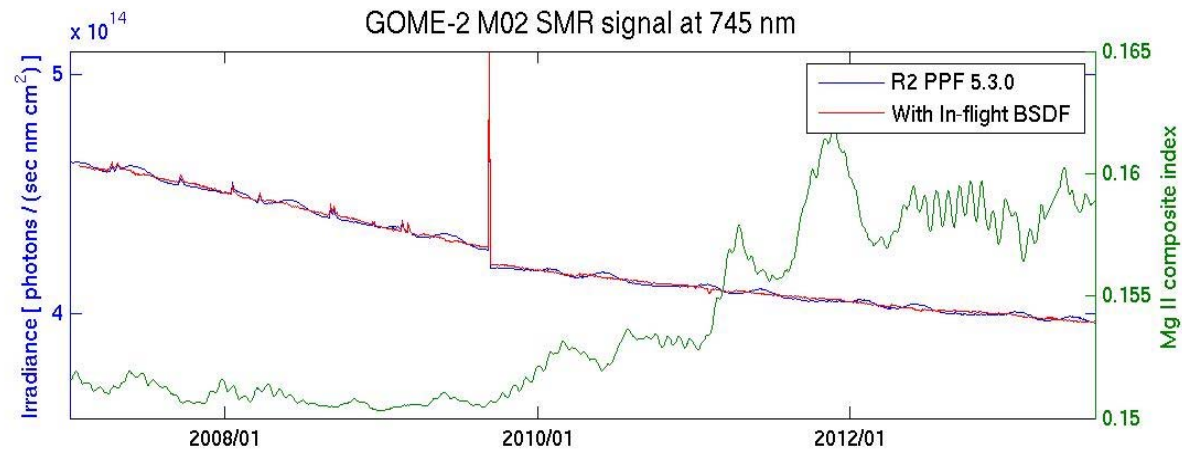

AOD / volcanic ash retrieval from two Metop – PMAp

Multi-sensor aerosol properties retrieval using GOME-2 PMDs (I,q), AVHRR and IASI

GOME-2 FM3
Metop-A

GOME-2 FM2
Metop-B

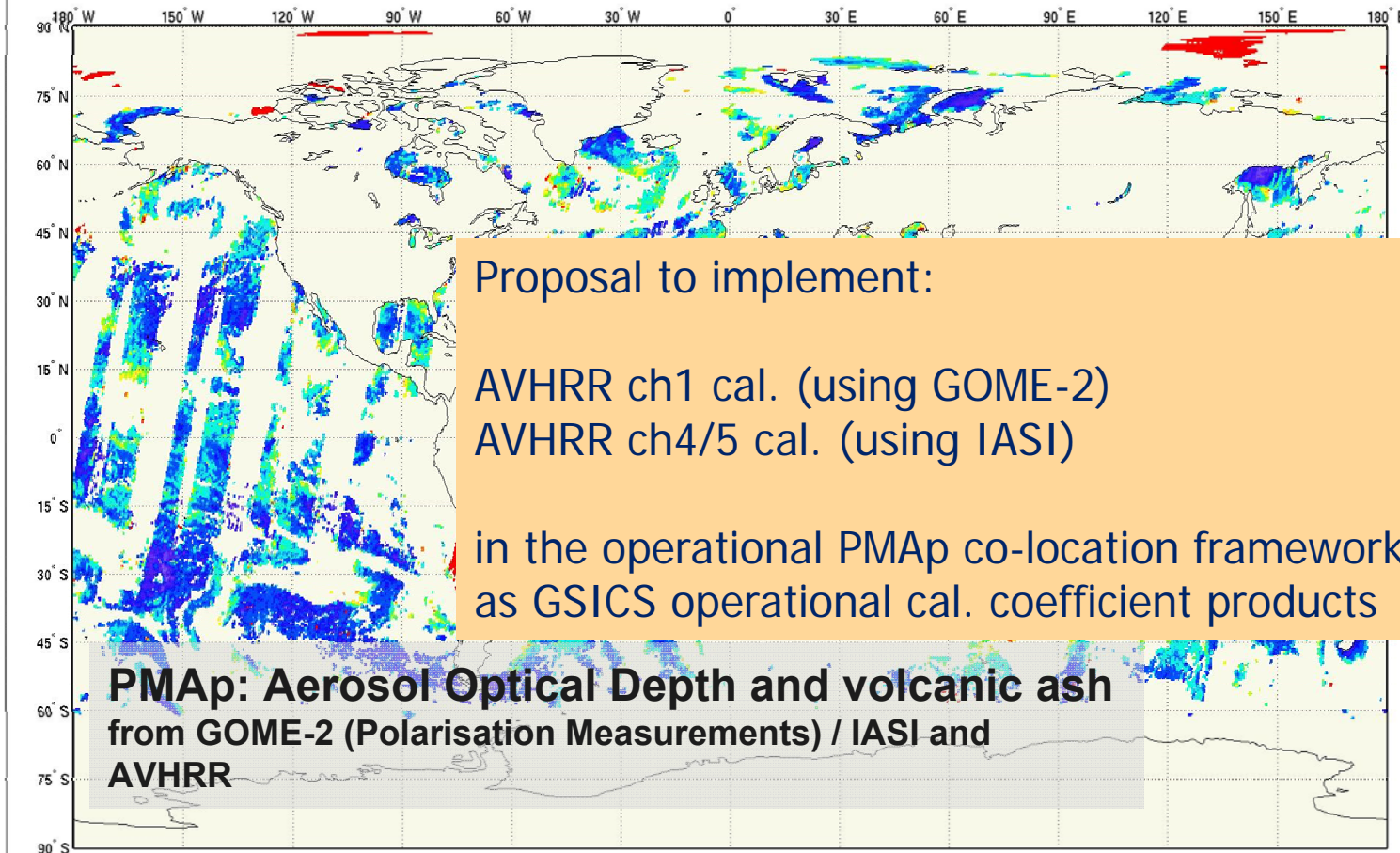

Proposal to implement:

AVHRR ch1 cal. (using GOME-2)

AVHRR ch4/5 cal. (using IASI)

in the operational PMAp co-location framework as GSICS operational cal. coefficient products

PMAp: Aerosol Optical Depth and volcanic ash from GOME-2 (Polarisation Measurements) / IASI and AVHRR

GOME-2 PMD - ground pixel sizes

Metop-B: 10 by 40 km
Metop-A: 5 by 40 km

GOME-2 PMD
AVHRR

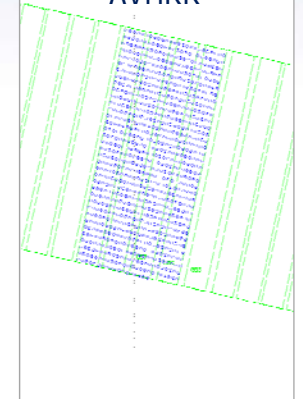

GOME-2 PMD
IASI

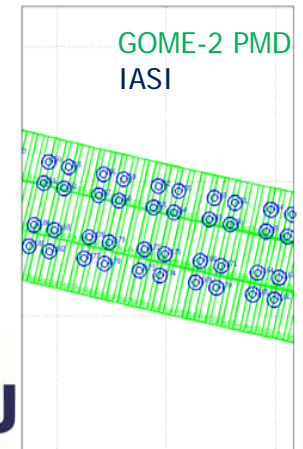

AOD / volcanic ash retrieval from two Metop – PMAp

Multi-sensor aerosol properties retrieval using GOME-2 PMDs (I,q), AVHRR and IASI

GOME-2 FM3
Metop-A

GOME-2 FM2
Metop-B

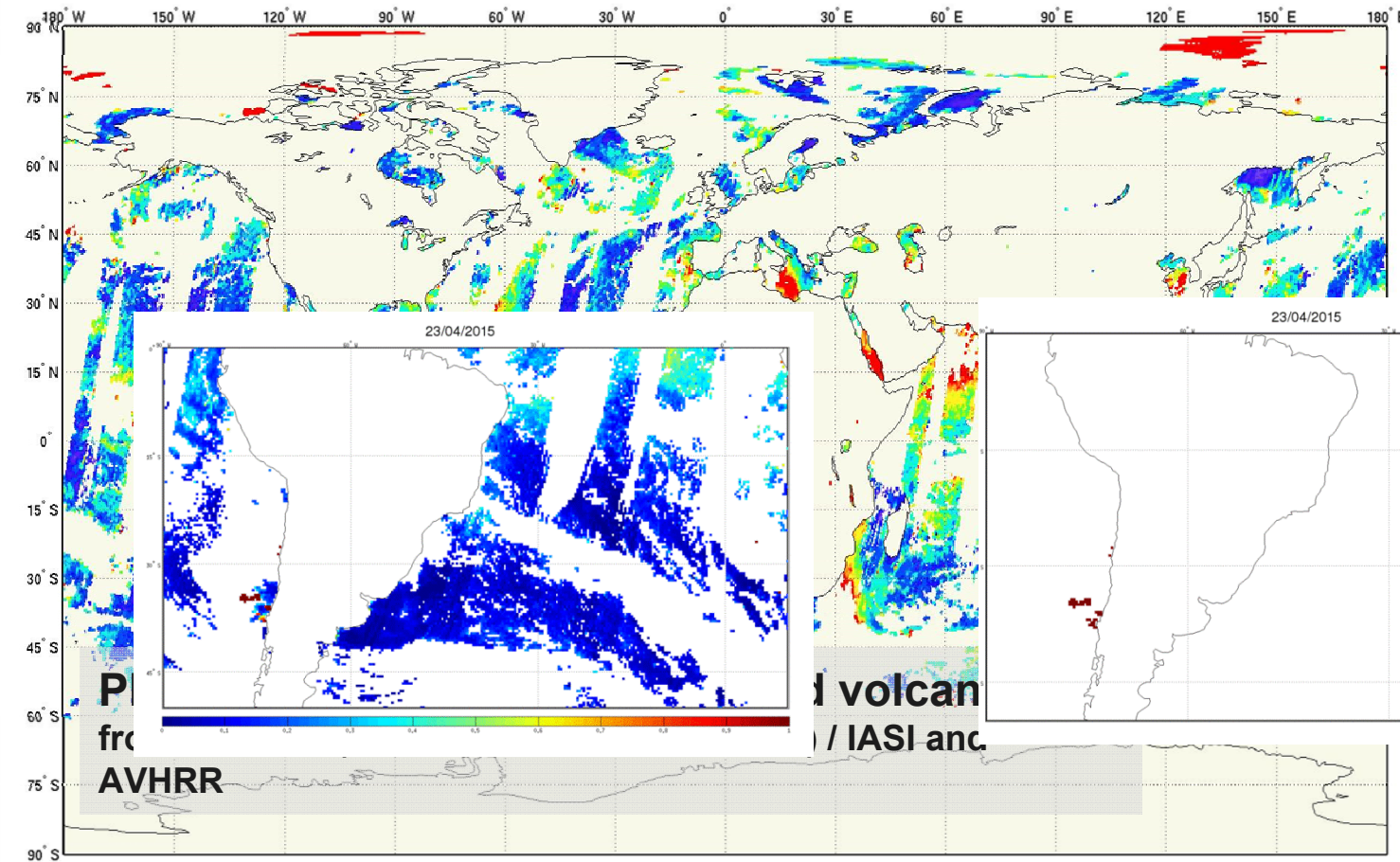

GOME-2 PMD -
ground pixel sizes

Metop-B: 10 by 40 km
Metop-A: 5 by 40 km

GOME-2 PMD
AVHRR

GOME-2 PMD

PMAp data available at: www.eumetsat.int > Data > Product Navigator

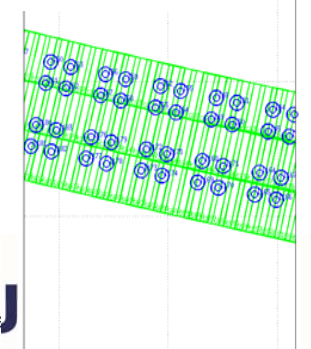



Summary

GOME-2 inter-calibration (AVHRR/Seviri/PMAp)

- GOME-2 / Metop-A channel 3/4 vs AVHRR / Metop-A channel 1

Scale factor of 0.89

(2007 to 2011, 2011 to 2013 after correction of GOME-2 data, spatial aliasing accounted for by empirical correlation optimisation)

- GOME-2 / Metop-B channel 3/4 vs Seviri / MSG-3 channel 1

Scale factor of ~0.92

(2013, no correction of GOME-2 data, no spatial aliasing)

- PMAp: GOME-2/(IASI) AVHRR inter-calibration

Towards continuous (operational) calibration for consistency with GOME-2 main science channels

- AVHRR inter-calibration of GOME-2 geo-reference data

Calibrating aspects of spatial aliasing and its radiometric effect in GOME-2 radiances by using AVHRR co-relation statistics



PMAp – Multi-sensor co-location for aerosol optical depth retrievals

GOME-2 FM3
Metop-A

GOME-2 FM2
Metop-B

Instr umen t		Spatial resolution	Spectral range	comments
GOME	Main science channel	80 x 40 km	240nm -800nm, res. 0.25-0.5nm	AAI, low spatial resolution, not used
	Polarization Monitoring Device	10 x 40 km Metop-B 5 x 40 km Metop-A	311nm-803nm, 15 bands	AOD, aerosol type, AAI
AVHRR	-	1.08 x 1.08 km	580nm-12500nm, 5 bands	Clouds, scene heterogeneity, dust/ash
IASI	-	12km (circular)	3700–15500nm, resolution 0.5 cm ⁻¹	desert dust, volcanic ash aerosol heights
Auxiliary data	ECMWF wind speed (forecasting)	Temporal interpolation necessary	-	Required for retrievals over ocean
	surface albedo, Surface elevation	-	Target spatial resolution	Required for retrievals over land



PMAp – Multi-sensor co-location for aerosol optical depth retrieval

The GOME-2 Polarisation Measurement Devices

GOME-2 FM3
Metop-A

GOME-2 FM2
Metop-B

Band-S				
No.	pix1	pixw.	wav1	wav2
1	22	5	311.709	314.207
2	30	4	316.762	318.720
3	37	12	321.389	329.139
4	50	6	330.622	334.443
5	57	6	336.037	340.161
6	84	17	360.703	377.873
7	102	4	380.186	383.753
8	117	19	399.581	428.585
9	138	27	434.083	492.066
10	165	18	494.780	548.756
11	183	2	552.474	556.262
12	187	11	568.070	612.869
13	198	9	617.867	661.893
14	218	4	744.112	768.269
15	224	2	794.080	803.072

- Radiances & Stokes fraction
- better spatial resolution
- Stokes fraction $s = Q/I$

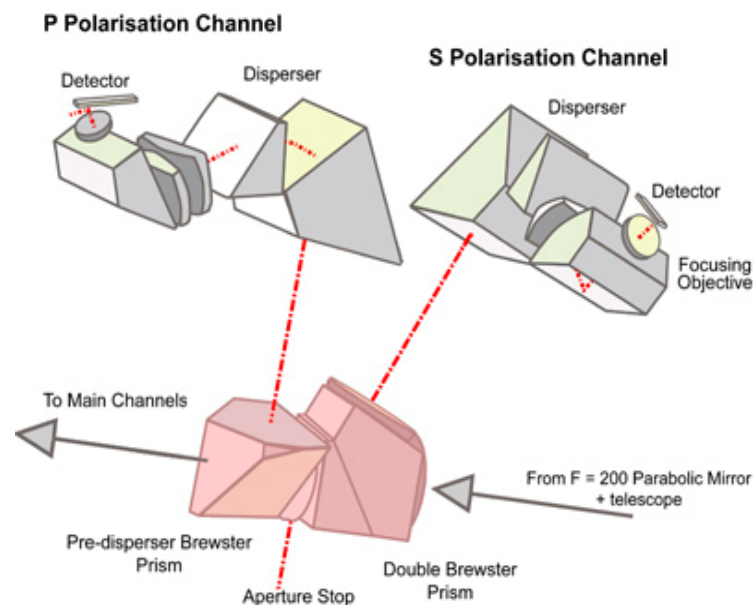

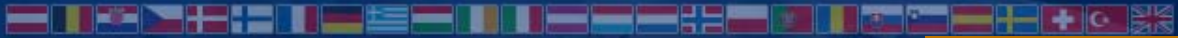

PMaP – Multi-sensor co-location for aerosol optical depth retrievals

The GOME-2 PMD / AVHRR / IASI co-location

GOME-2 FM3
Metop-A
GOME-2 FM2
Metop-B

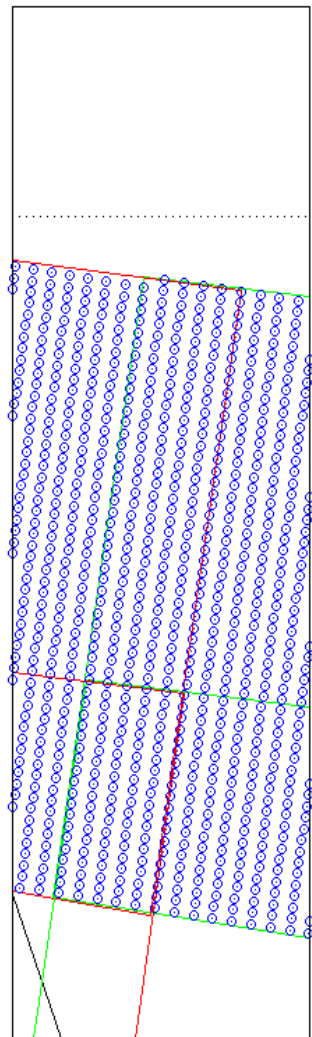

AVHRR collocation:
an AVHRR pixel is collocated to a GOME-2 PMD pixel if it is inside the GOME-2 pixel

Spatial aliasing due to read-out timing of detectors is taken into account!

IASI collocation:
a IASI pixel may span up to 6 GOME-2 PMD pixels. Which GOME-2 pixel should it be collocated to?

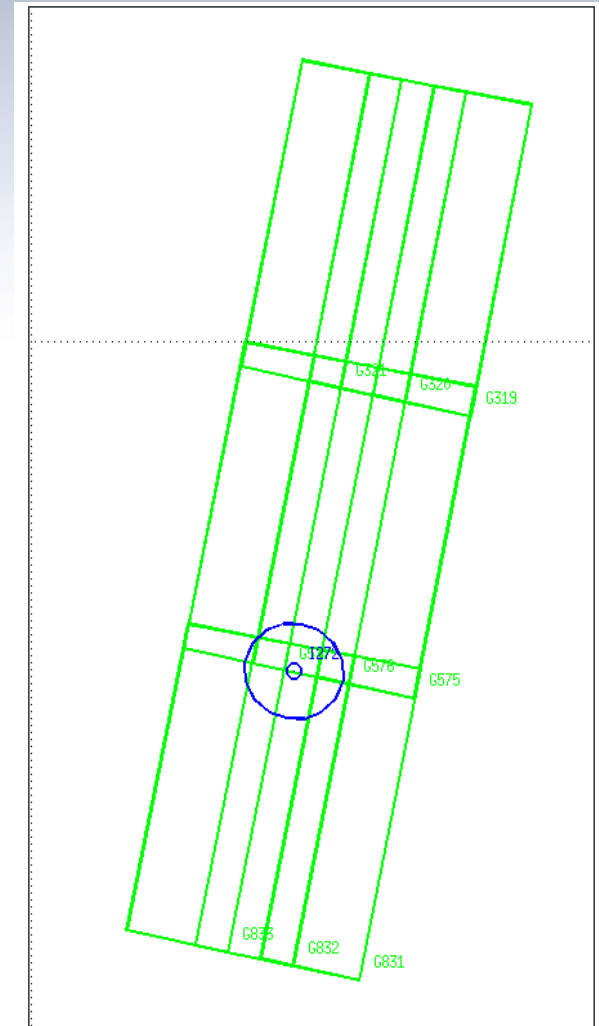

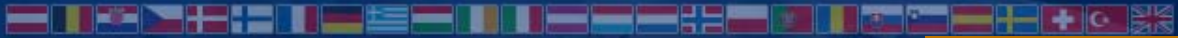

PMAp – Multi-sensor co-location for aerosol optical depth retrieval

Towards continuous calibration of AVHRR channels

GOME-2 FM3
Metop-A

GOME-2 FM2
Metop-B

For PMAp a consistent and continuous AVHRR – GOME-2/IASI radiometric inter-calibration is needed!

AVHRR channels

Channel	Central wavelength [μm]	Wavelength range [μm]
1	0.630	0.580 - 0.680
2	0.865	0.725 - 1.000
3A	1.610	1.580 - 1.640
3B	3.740	3.550 - 3.930
4	10.800	10.300-11.300
5	12.000	11.500-12.500

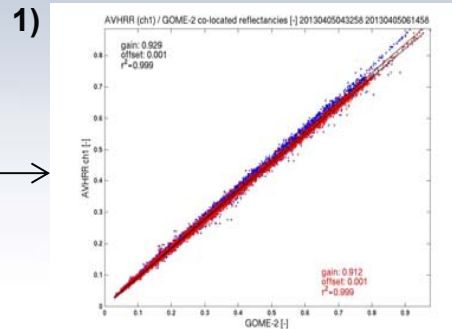

AVHRR vs GOME-2:
Use GOME-2
Main channels to
calibrate AVHRR
ch 1 and 2

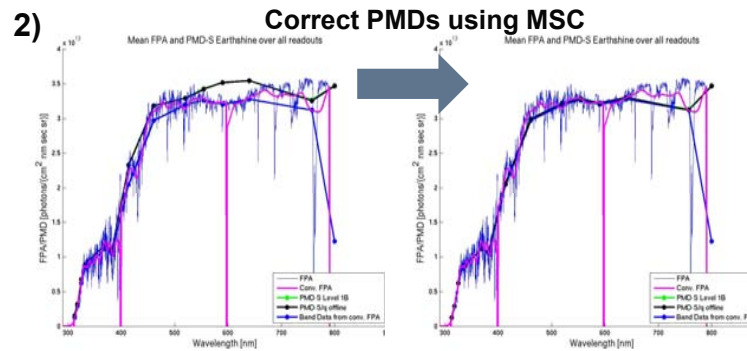

GOME-2 PMD vs Main channels (MSC):
Make PMDs consistent with main science channel radiances

3) **AVHRR vs IASI:**
Use IASI to calibrate AVHRR ch 3 to 5

GOME-2 Metop-A degradation component modelling

Sahara – Reflectivity Degradation / AVHRR ch1-domain

GOME-2 FM3
Metop-A

Normalised Earthshine & SMR Correction Coeff. over Viewing Position Ch.: 4 at 640 nm Sahara

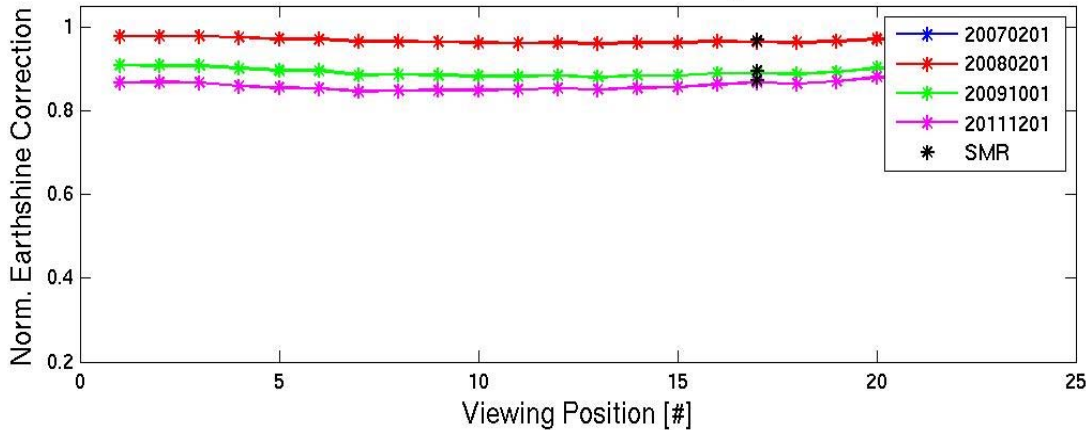

Normalised Reflectivity Correction Coeff. from Earthshine/SMR over Viewing Position Ch.: 4 at 640 nm Sahar

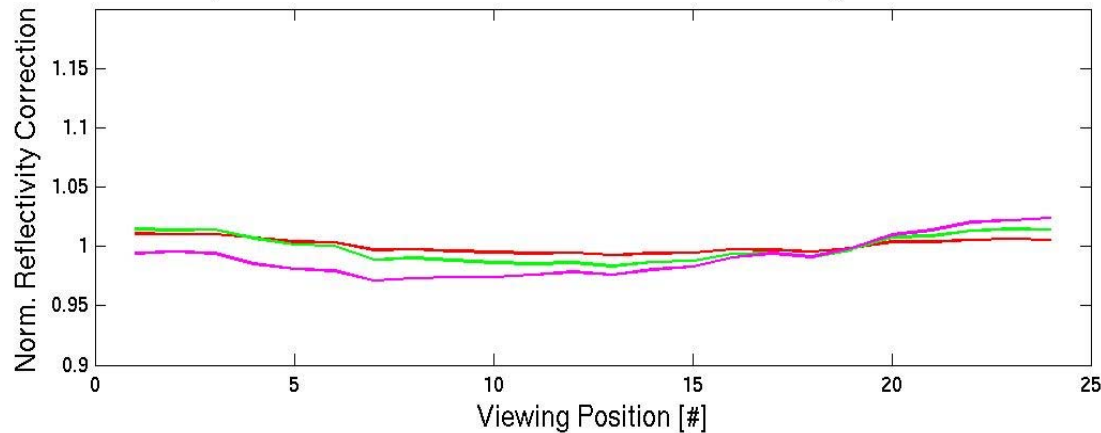

R2 campaign
Jan 2007– Jan 2012
OPS phase (same PPF 5.3)
Jan 2012 – Oct 2013

Reflectivity
Degradation

640 nm

Over all
GOME-2 viewing
angles

at

2008/02/01
2009/10/01
2011/12/01

Metop-A/B GOME-2 inter-calibration

Earthshine measurement co-location to Metop-A / FM3 / Radiances

GOME-2 FM3
Metop-A

GOME-2 FM2
Metop-B

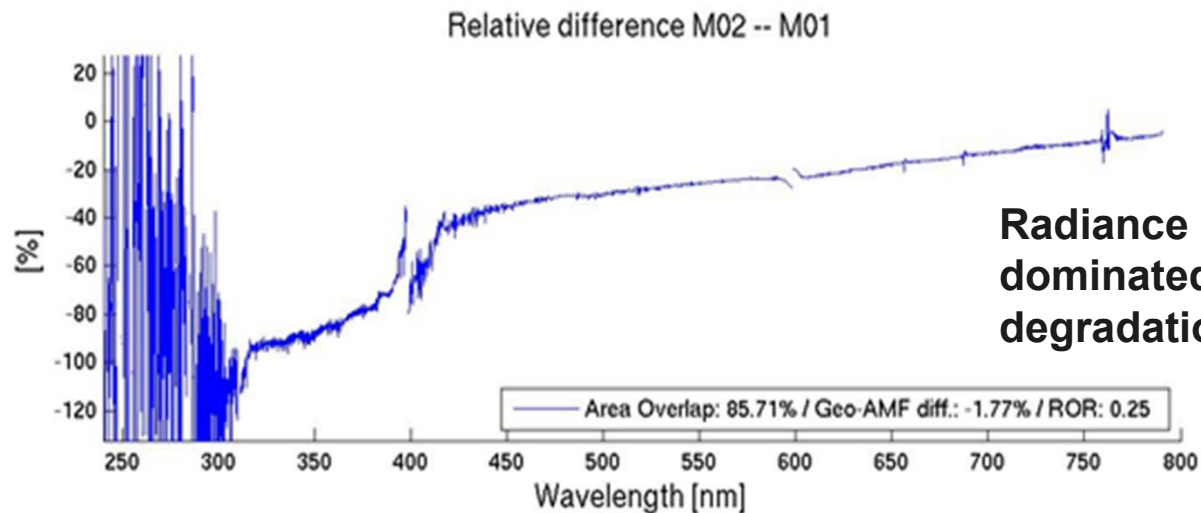
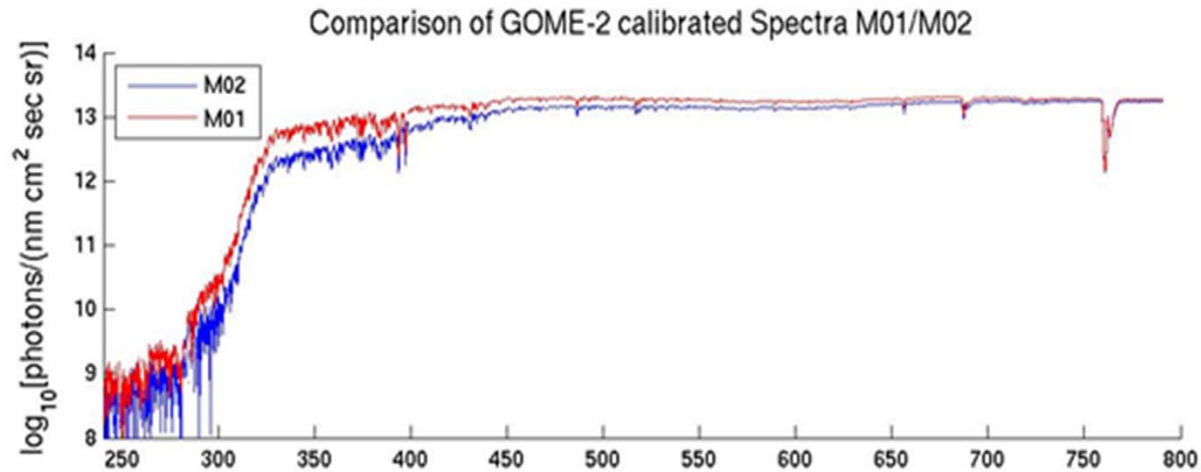

Radiance residuals are dominated by FM3 degradation signature

Metop-A/B GOME-2 inter-calibration

Earthshine co-located Metop-A/B residuals

Background predominantly from Metop-A degradation

GOME-2 FM3
Metop-A

GOME-2 FM2
Metop-B

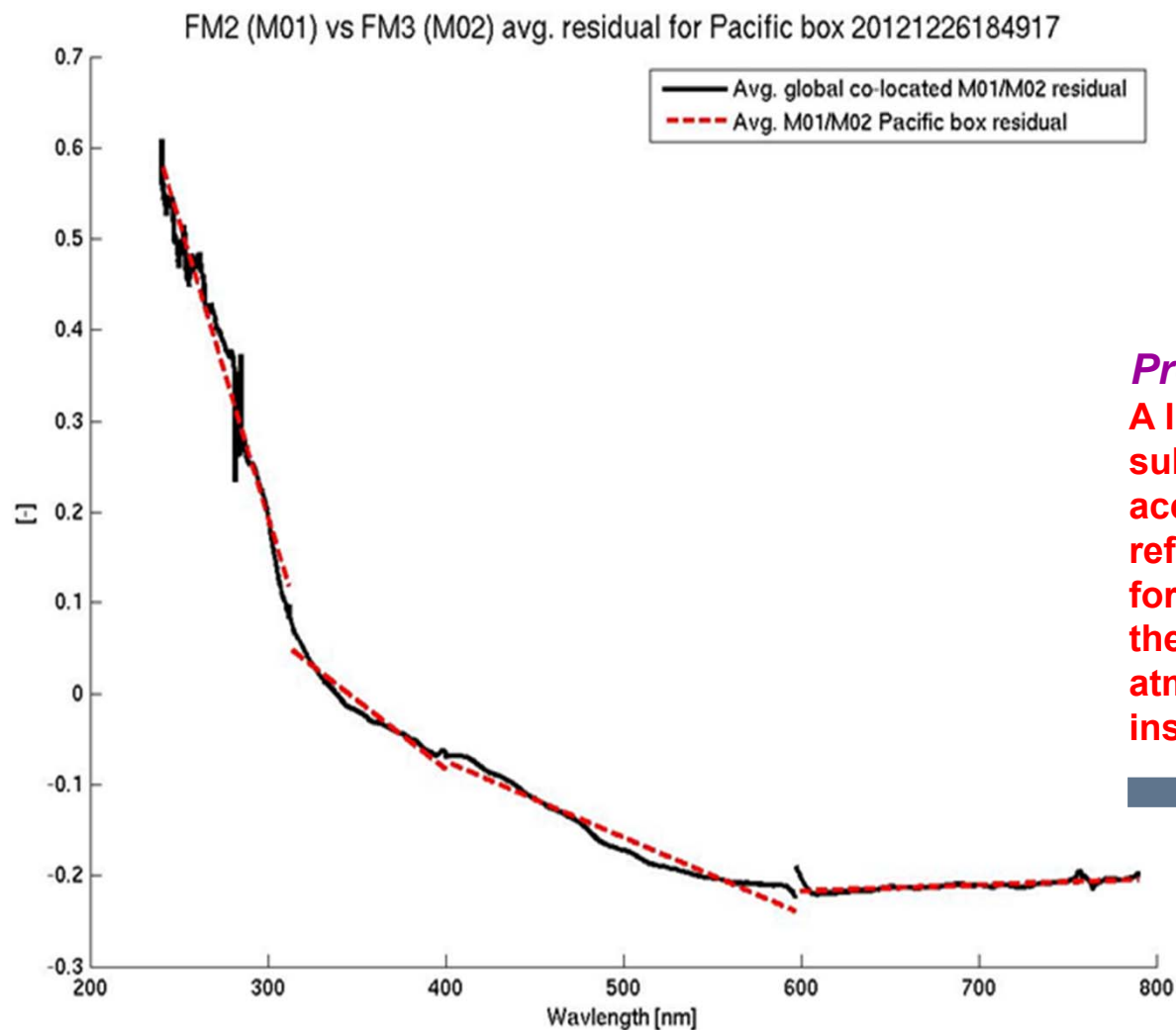

Example for an average over multiple FM2/FM3 residuals in reflectivity.

Prelim. Approach:

A linear background is subtracted per channel to account for the difference in reflectivity-degradation and for broad-band differences in the different observed atmospheric paths per instrument.



Looking for the small scale structures per channel



GOME-2/Metop-B reflectivity inter-calibration

SEVIRI ch1/ MSG-3 – preliminary results

GOME-2 FM2
Metop-B

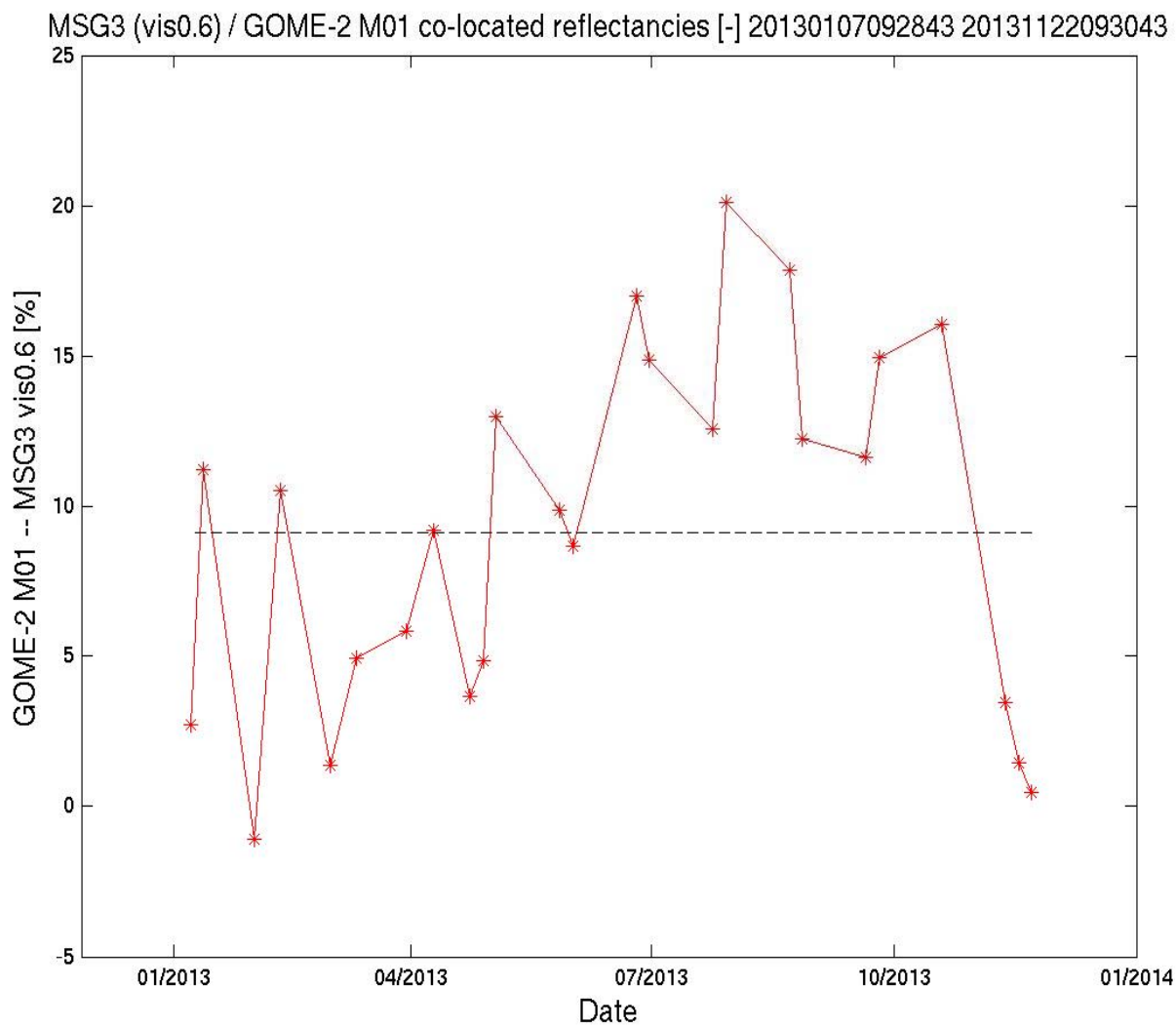

**MSG-3 / Seviri ch 1 to
GOME-2/Metop-B
gain in reflectivity
~8.5%
(Seviri < GOME-2)**

**1st Jan to 22nd Nov
2013**

*No spatial aliasing
correction yet*

*No correlation with
SZA found*

GOME-2 Metop-A degradation component modelling

Sahara reflectivity – spectral and temporal domain

GOME-2 FM3
Metop-A

Normalised and Spectrally smoothed Trend Reflectivity FPAs View Pos: 1 Sahara

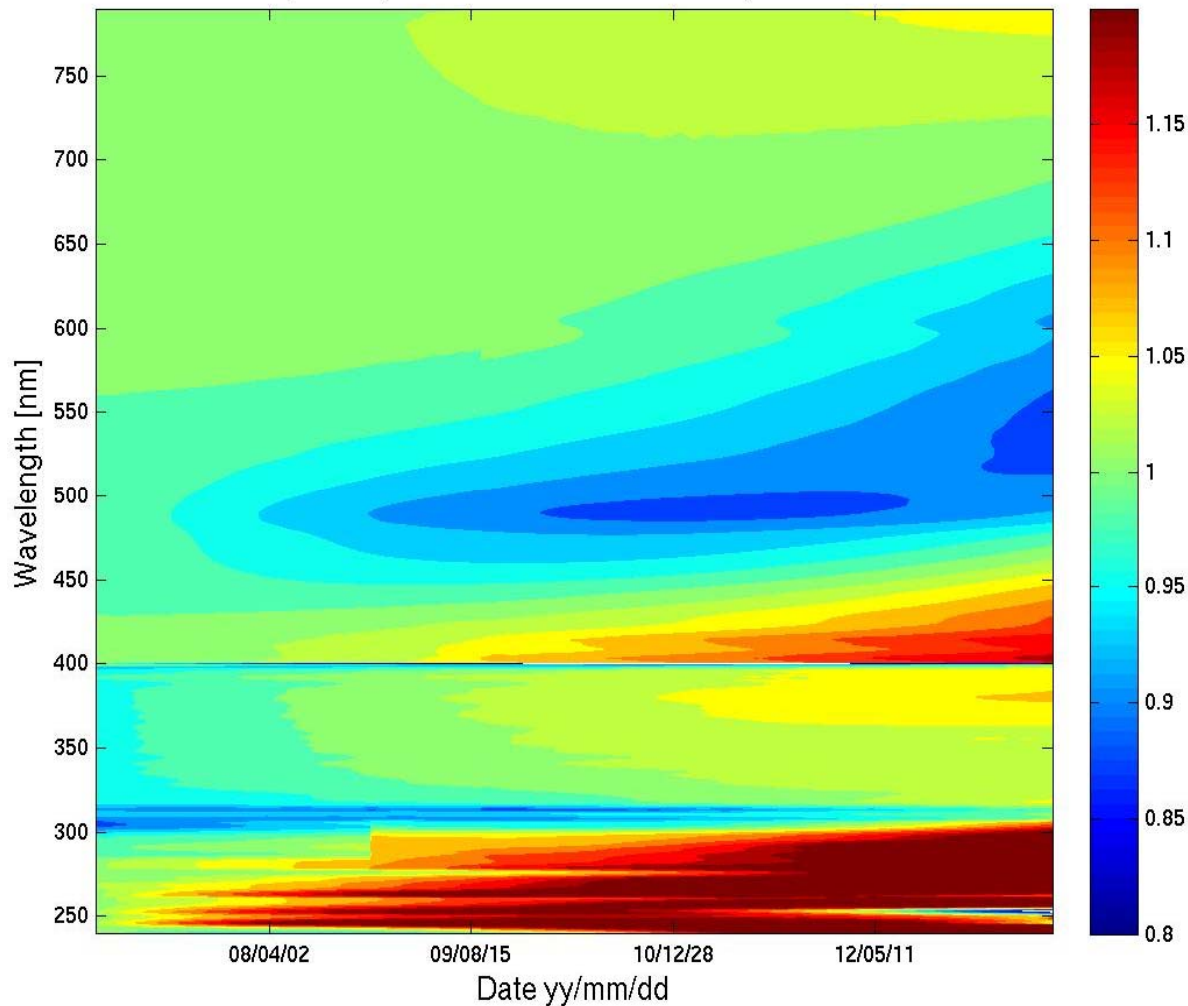

R2 campaign
Jan 2007– Jan 2012
OPS phase (same PPF 5.3)
Jan 2012 – Oct 2013

Reflectivity Trend